

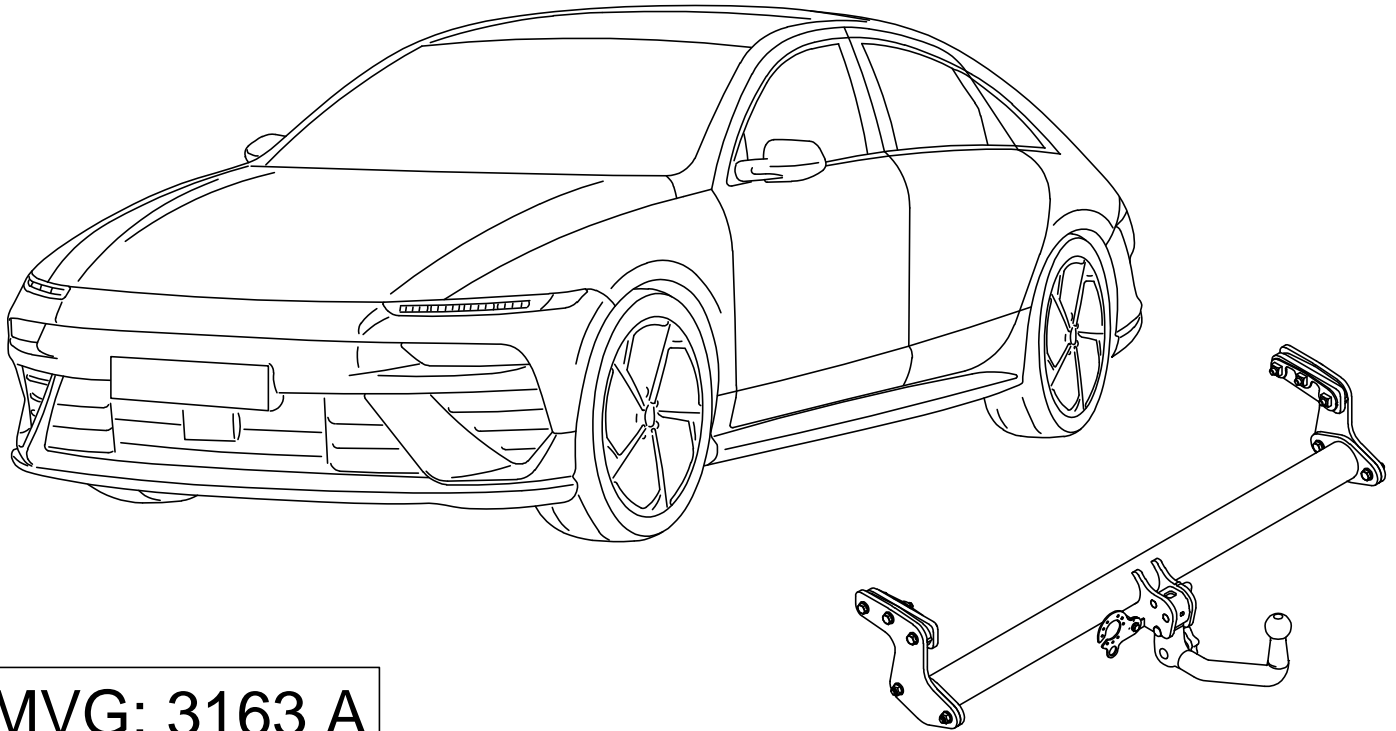

Die Anhängerkupplung.

Anhängerkupplungen  
und Elektrosätze  
direkt vom Hersteller



MVG: 3163 A

Hyundai IONIQ 6 Facelift / N-Line (CE) Mj 2026à

**D** Einbauanleitung

**GB** Installation instruction

**F** Notice de montage

**I** Istruzioni di montaggio

**E** Instrucciones de montaje

**CZ** Návod k montáži

**NL** Inbouw instructie

**S** Monteringsanvisning

## MVG-Metallverarbeitungsgesellschaft mbH

An der Wasserwiese 1  
52249 Eschweiler  
Deutschland

Tel.: +49 (0) 2403 7902-60  
E-Mail: [info@mvg-ahk.de](mailto:info@mvg-ahk.de)

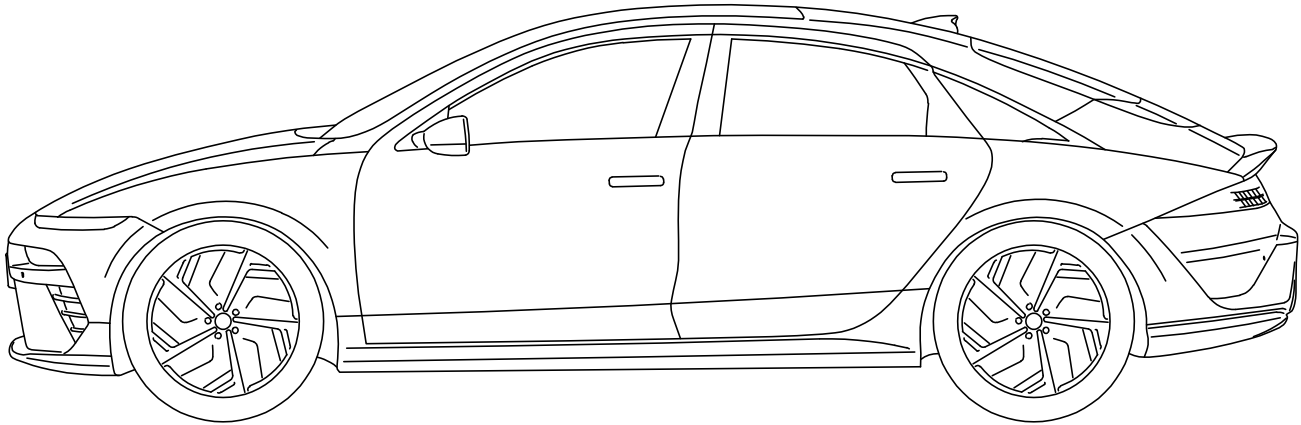
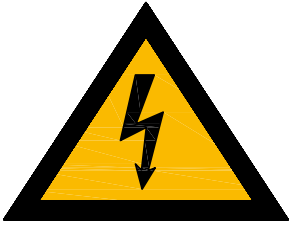

## Hyundai IONIQ 6 Facelift / N-line Mj 2026à

### **Achtung!**

Bei diesem Fahrzeugmodell handelt es sich um ein Fahrzeug mit gefährlicher Hochspannung. Bei unsachgemäßer Handhabung kann es durch Stromschlag oder Kurzschluss zu lebensgefährlichen Auswirkungen kommen. Achten Sie auf die ausreichende Qualifikation des Mitarbeiters bei Arbeiten an Fahrzeugen mit Hochvolt-System. Lesen Sie die Warn- und Sicherheitshinweise im Werkstattinformationssystem. Führen Sie ausschließlich die in dieser Anleitung beschriebenen Arbeitsschritte durch. Trennen Sie keine orangefarbenden Kabel. Achten Sie auf Warnsymbole wie einen Hochvoltblitz!



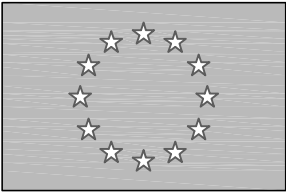

EG

e4 \* 2018/858 \* 00145

D = 10,0 kN

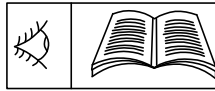

≤ 100 kg

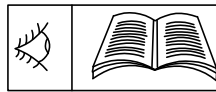
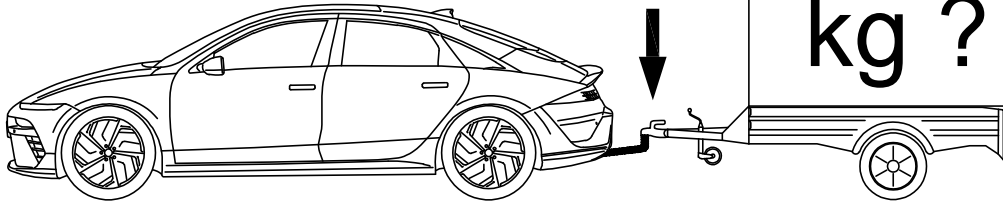

≤ 75 kg

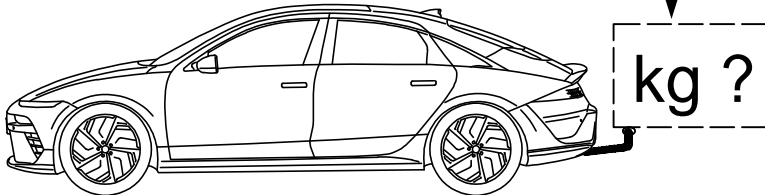

max. Gewicht beachten!  
Note Capacity!

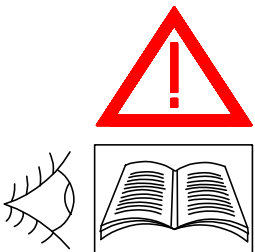

$$\text{kg ?} + \begin{matrix} \text{kg} \\ \text{max. 2} \end{matrix} = 75 \text{ kg}$$

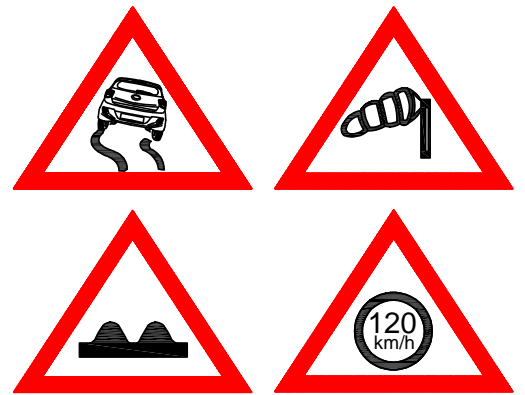

1x

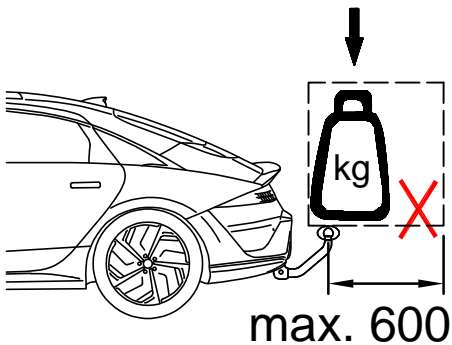

max. 2x

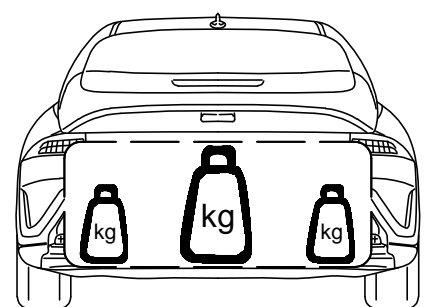
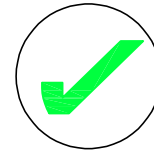
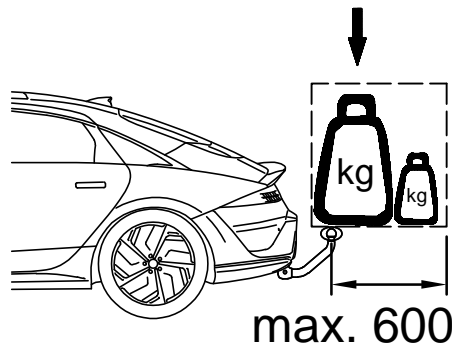

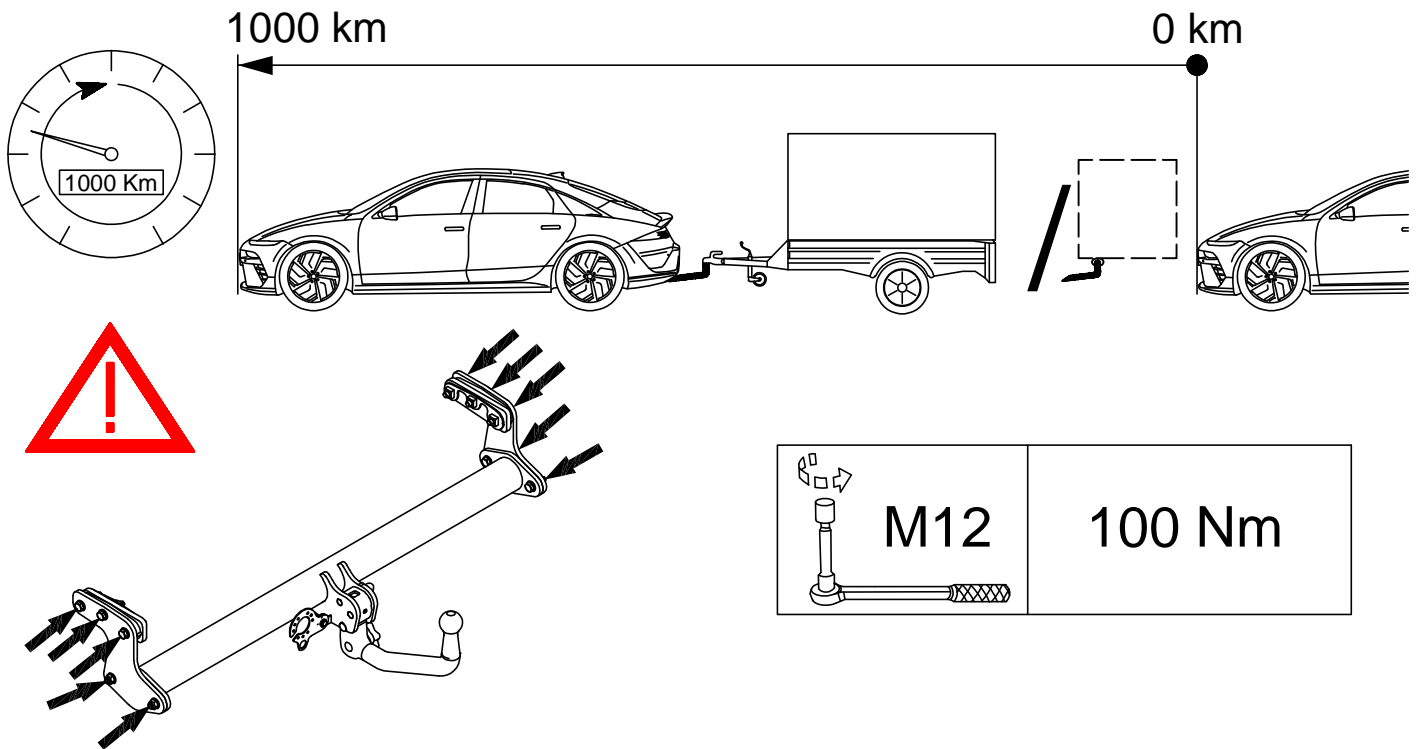
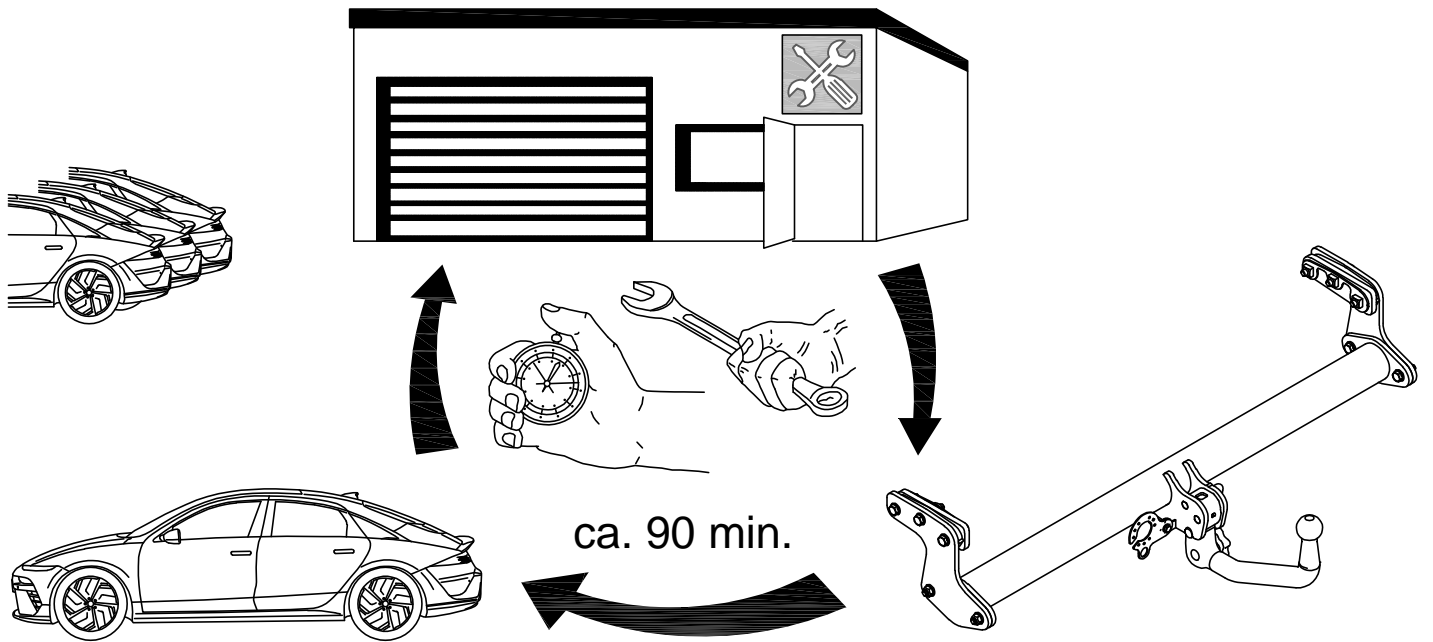

$$D = \frac{T \times R}{1000 \times (T + R)} \times g$$

$$g = 9,81 \text{ m/s}^2$$

$$T = \frac{R \times D \times 1000}{(g \times R) - (1000 \times D)}$$

$$R = \frac{T \times D \times 1000}{(g \times T) - (1000 \times D)}$$

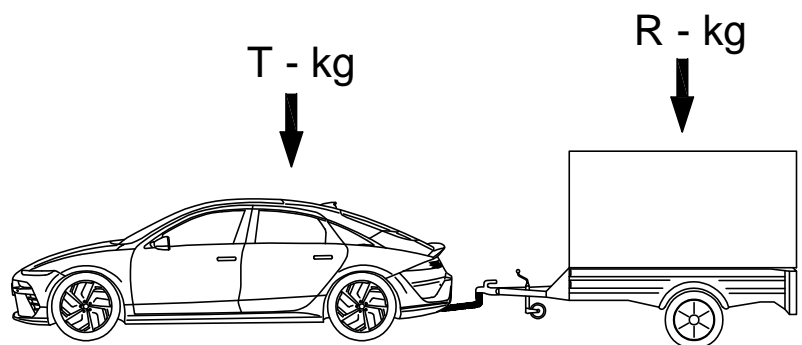

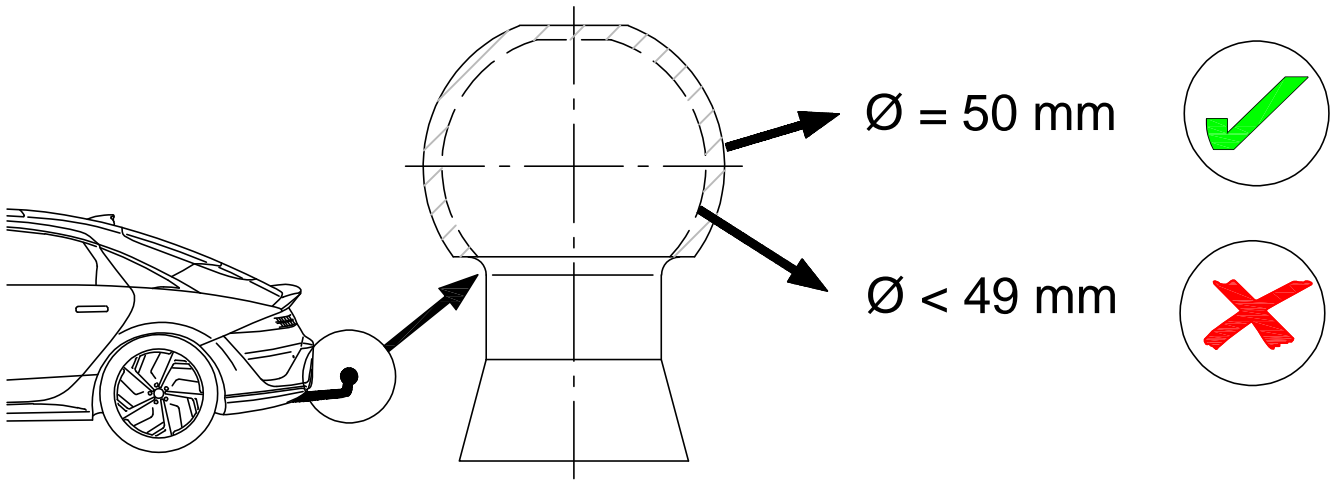

**MVG**<sup>®</sup> Approval Number  
 MVG-Metalverarbeitungsgesellschaft mbH **E4** 55R-03 1476  
 Type: 3163 A D-Value: 10,0 kN  
 Class: A50-X S-Value: 100 kg  
 Made in Germany [www.mvg-ahk.de](http://www.mvg-ahk.de)

Zulässige Stützlast  
 maximal 100 kg

**MVG**<sup>®</sup>  
 MVG-Metalverarbeitungsgesellschaft mbH  
[www.mvg-ahk.de](http://www.mvg-ahk.de)

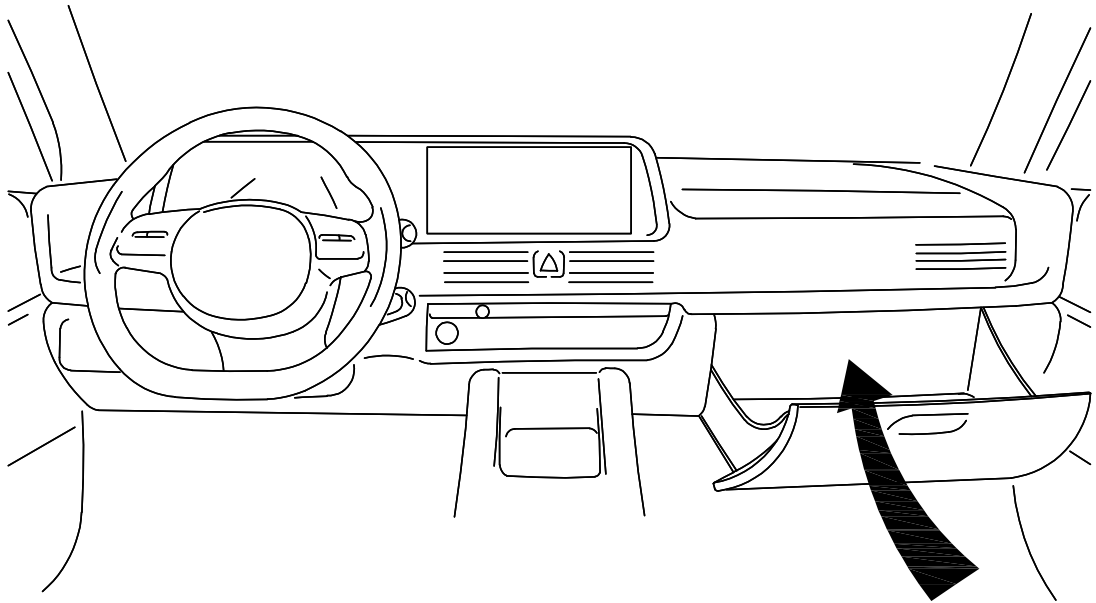

Technische Änderungen vorbehalten

**MVG**

MVG 3163 A  
 Hyundai (IONIQ & N-Line (CE))

✓	✓
✓	✓
✓	✓
✓	✓
✓	✓

MVG-Metalverarbeitungsgesellschaft mbH  
 An der Hauptstraße 1 34123 Ahk (Hess.)  
 Tel. +49 (0) 561 9394-0  
 Fax +49 (0) 561 9394-100  
 E-Mail [info@mvg-ahk.de](mailto:info@mvg-ahk.de)











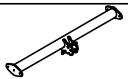

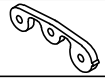
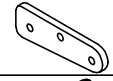
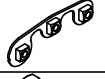

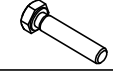





**MVG**

MVG-System: 2040

✓	✓
✓	✓
✓	✓
✓	✓
✓	✓

MVG-Metalverarbeitungsgesellschaft mbH  
 An der Hauptstraße 1 34123 Ahk (Hess.)  
 Tel. +49 (0) 561 9394-0  
 Fax +49 (0) 561 9394-100  
 E-Mail [info@mvg-ahk.de](mailto:info@mvg-ahk.de)

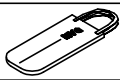
 <p>siehe Werkstatthandbuch</p>	 <p>Nicht Entsorgen</p>	 <p>Entsorgen</p>	 <p>Von Hand</p>
 <p>Achtung</p>	 <p>Bewegungspfeil</p>	 <p>Positionspfeil</p>	 <p>Stecker lösen/ verbinden</p>
 <p>Achtung Hochvolt</p>	 <p>Ohne Druckluft</p>	 <p>Nicht ölen</p>	 <p>Seitenschneider verwenden</p>
 <p>Nur zu zweit ausführen</p>	 <p>Festdrehen</p>	 <p>Siehe Abbildung</p>	 <p>Von Hand festdrehen</p>
 <p><b>CLEANER</b> Unterbodenschutz entfernen (Reinigen)</p>	 <p>Gegen Korrosion schützen</p>	 <p>Bohrer verwenden Ø8</p>	 <p>Kleben</p>
 <p>Anzeichnen</p>	 <p>Schneiden</p>	 <p>Feilen/ Entgraten</p>	 <p>Licht kontrollieren</p>

1	1x		3163 A		
2	1x		2040 A 041		
3	2x				
4	2x				
5	2x				
6	2x				
7	6x		M12x60 (10.9)	ISO 4017	
8	4x		M12x40 (10.9)	ISO 4017	
9	14x		Ø13/ 24x2,5	ISO 7089	
10	4x		M12 (10)	ISO 7042	
11	1x				
12	1x		M8x45 (8.8)	ISO 4017	
13	1x		Ø8,4/ 16x1,6	ISO 7089	
14	1x				
15	1x				
16	2x		Ø8,4/16x1,6 PA 6.6	DIN 125	
17	1x		M8 (8)	ISO 7042	
18	1x		3163 A		
19	1x		System 2040		
20	1x			0062	
21	1x		100 kg	1016	
22	1x			1012	
23	2x				

**D** Lieferumfang der Anhängervorrichtung

**GB** Scope of delivery of towing hitch

**F** Pièces comprises dans la fourniture de l'attelage

**I** Dotazione del gancio di traino

**E** Volumen de suministro del enganche

**CZ** Objem dodání tažného zařízení

**NL** Leveringsomvang trekhaak

**S** Dragkrokens leveransspecifikation



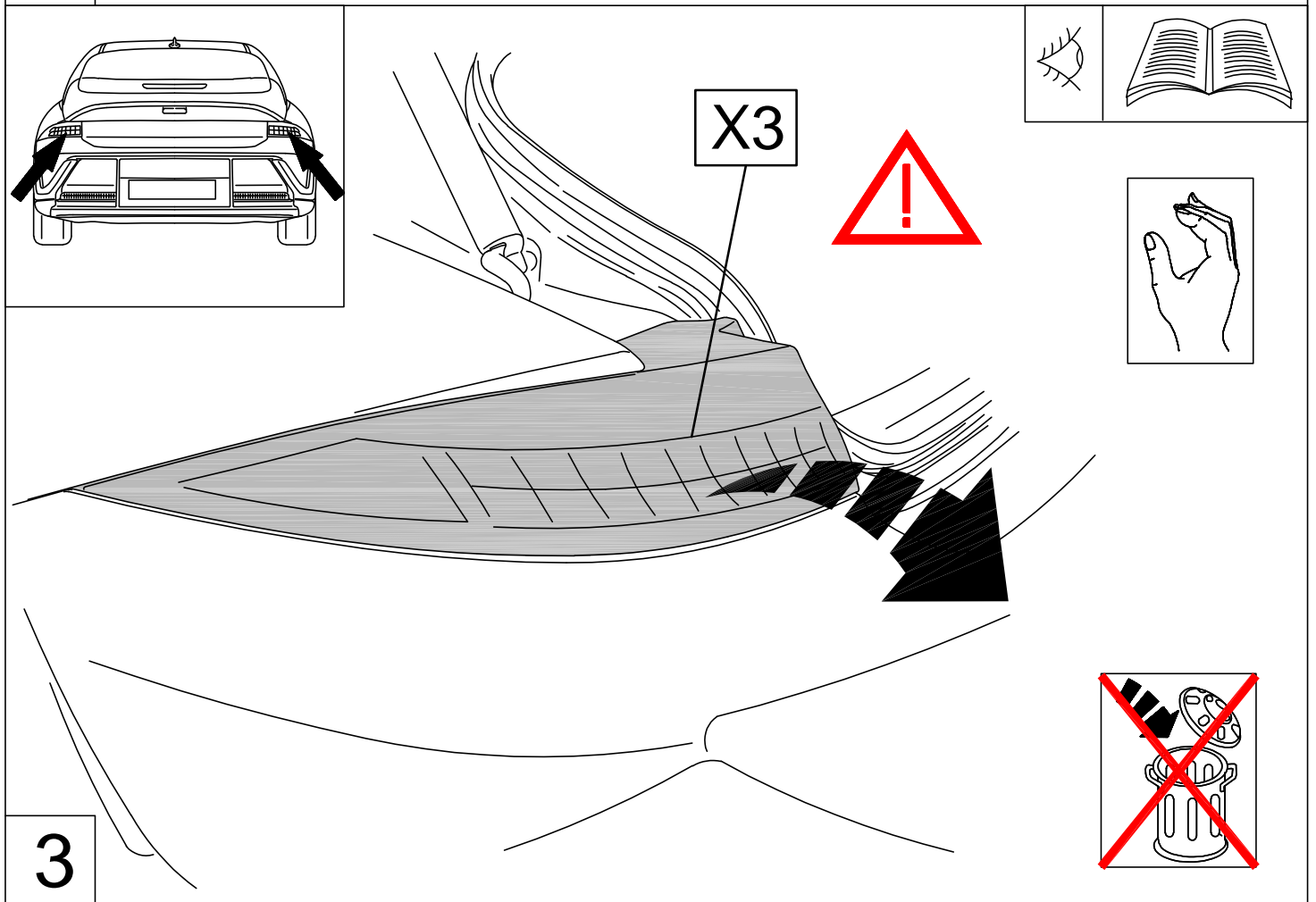
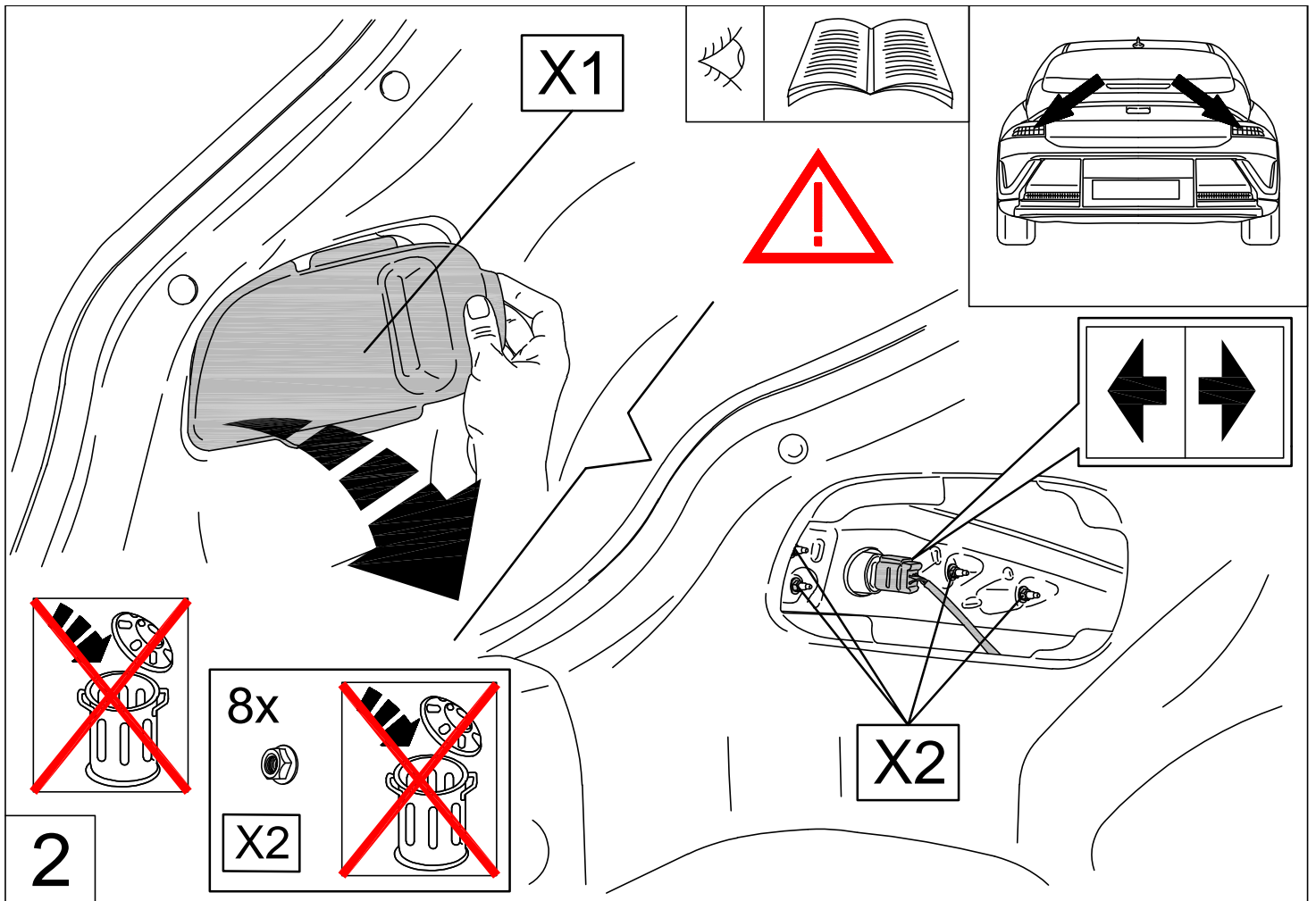

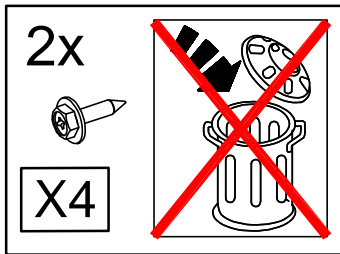
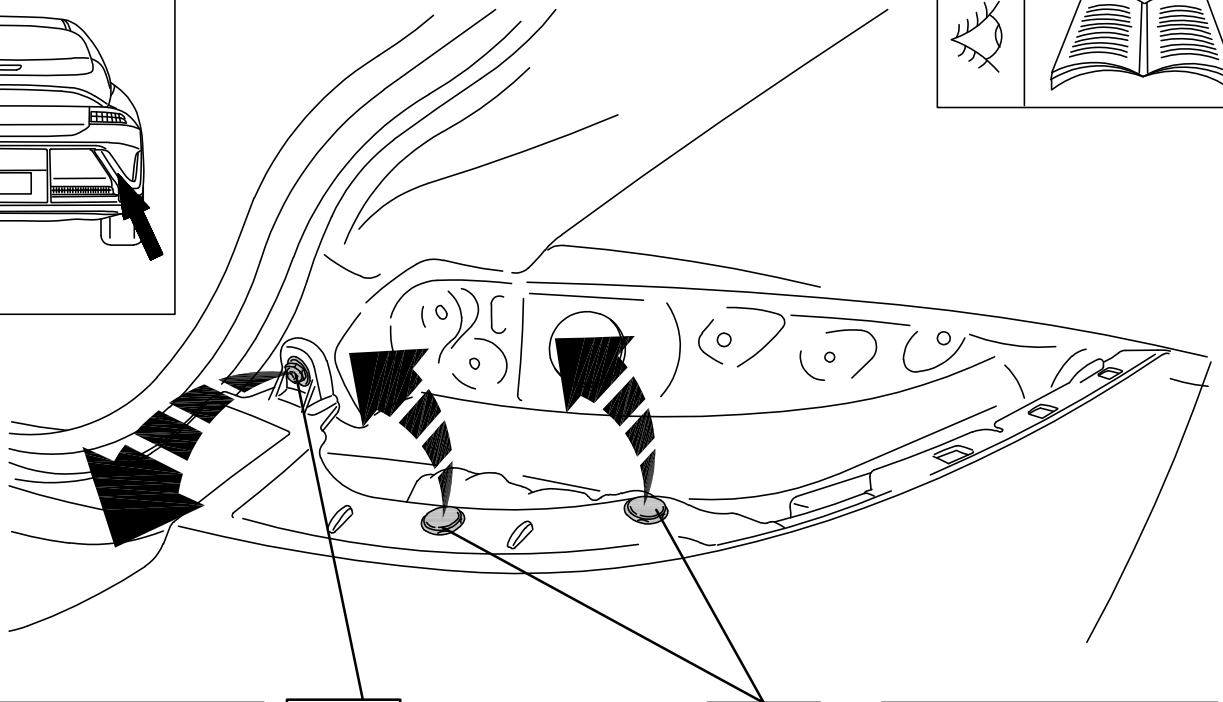
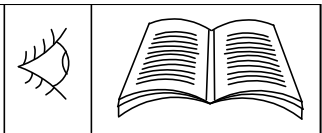
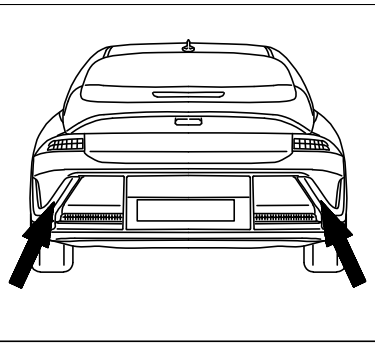

X4

X5

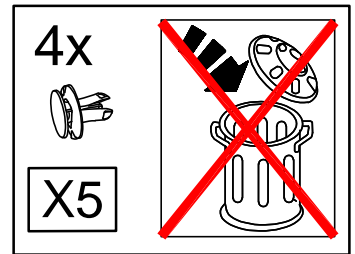

4

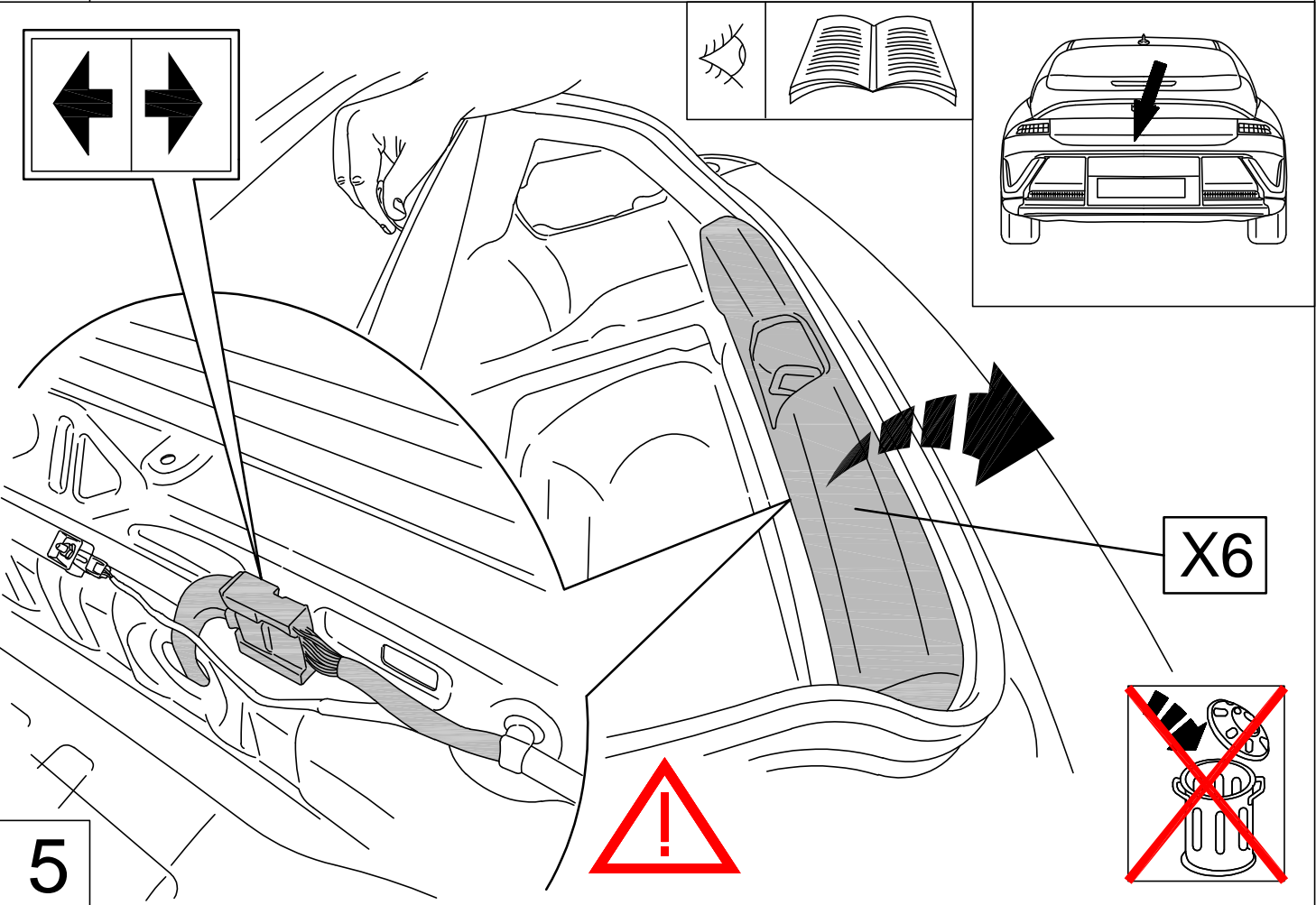
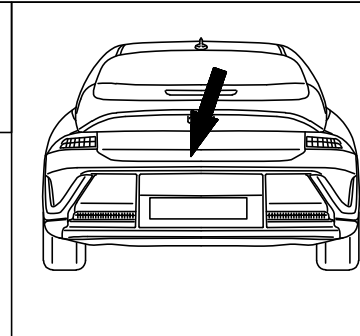
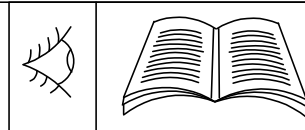
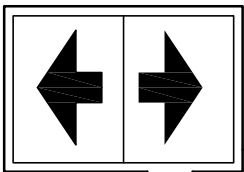

5

X6

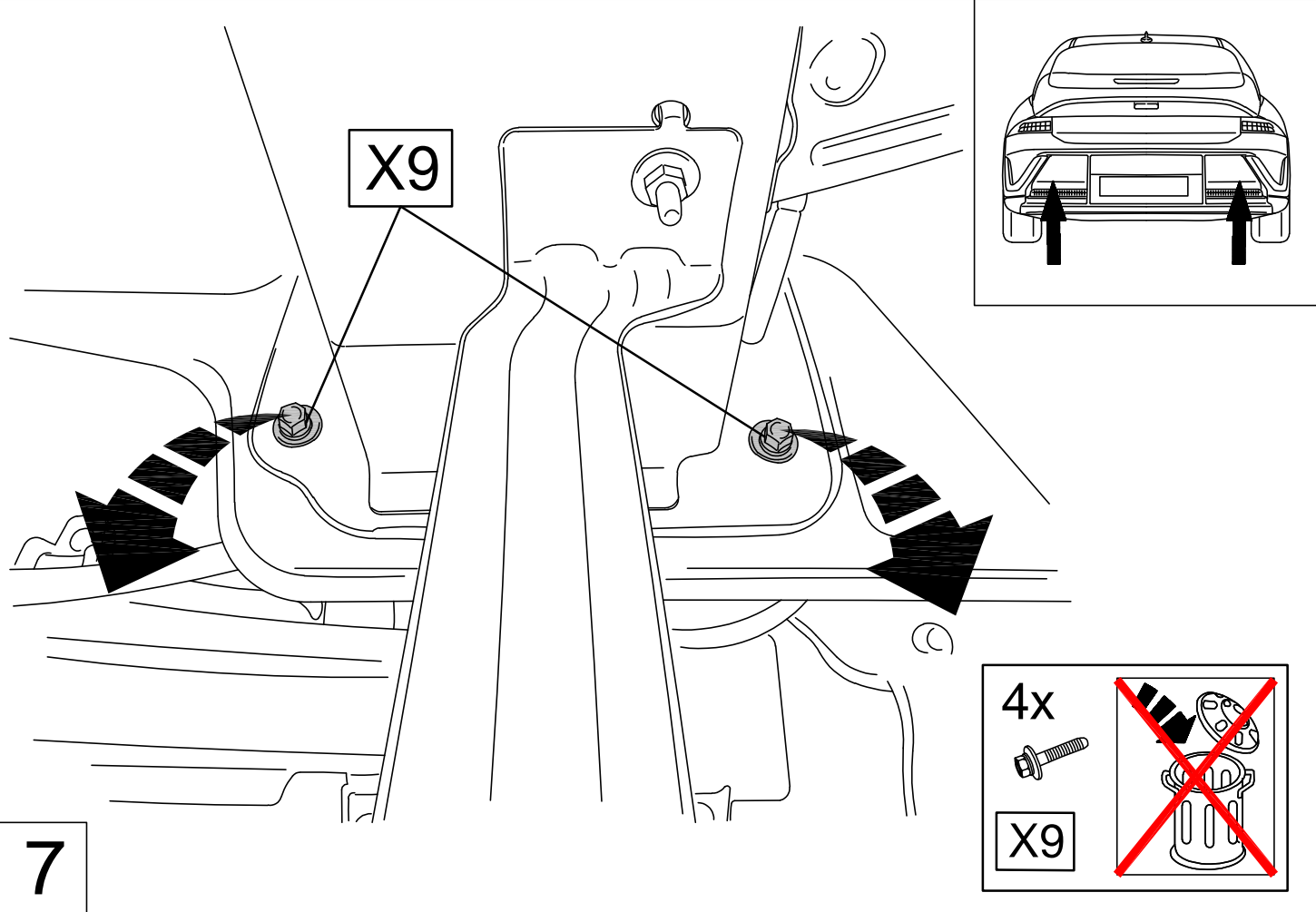
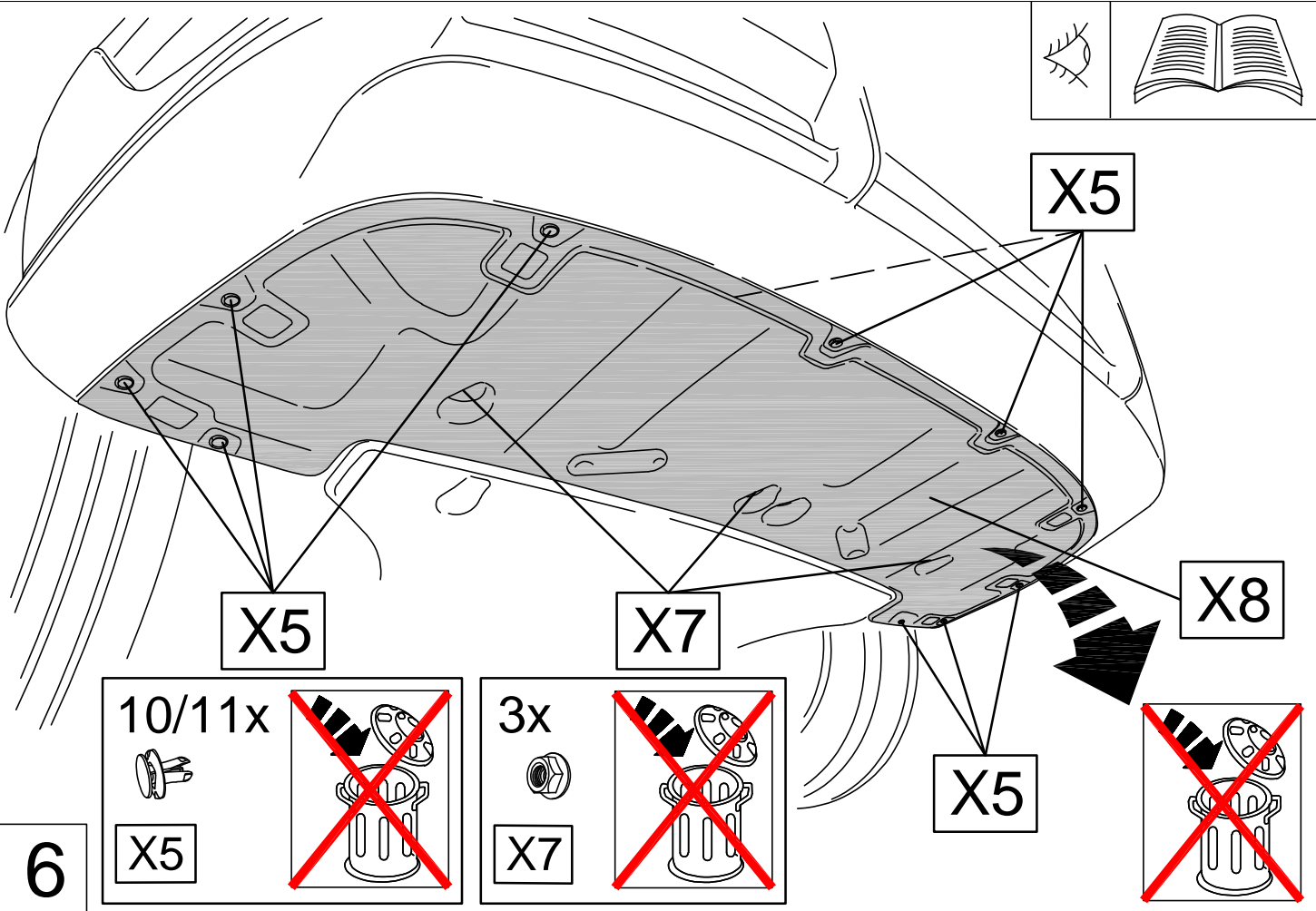
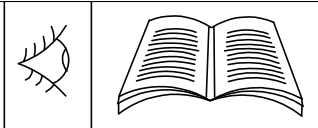

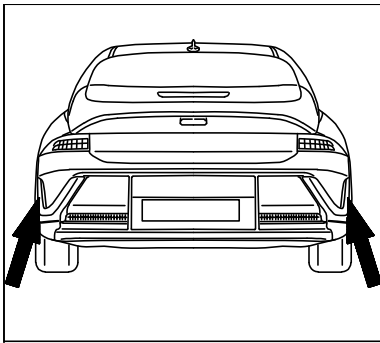

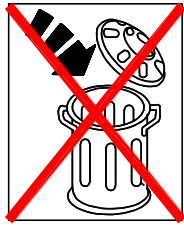

2x  

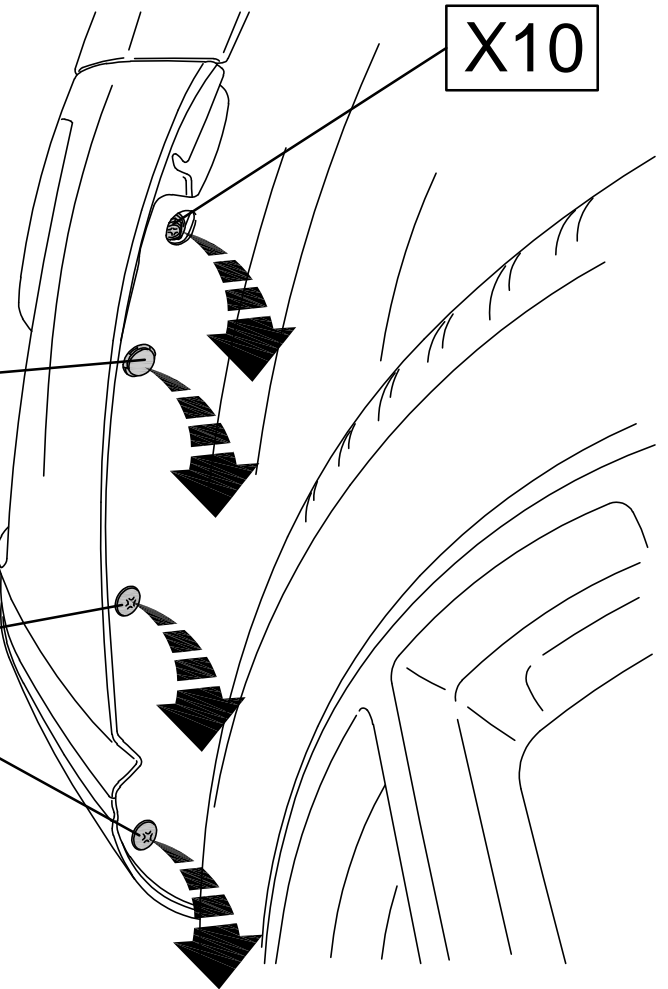
X10





X10

2x  

X5

X5

4x  

X11

X11

8

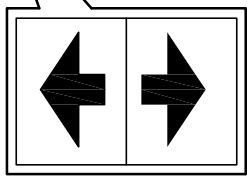
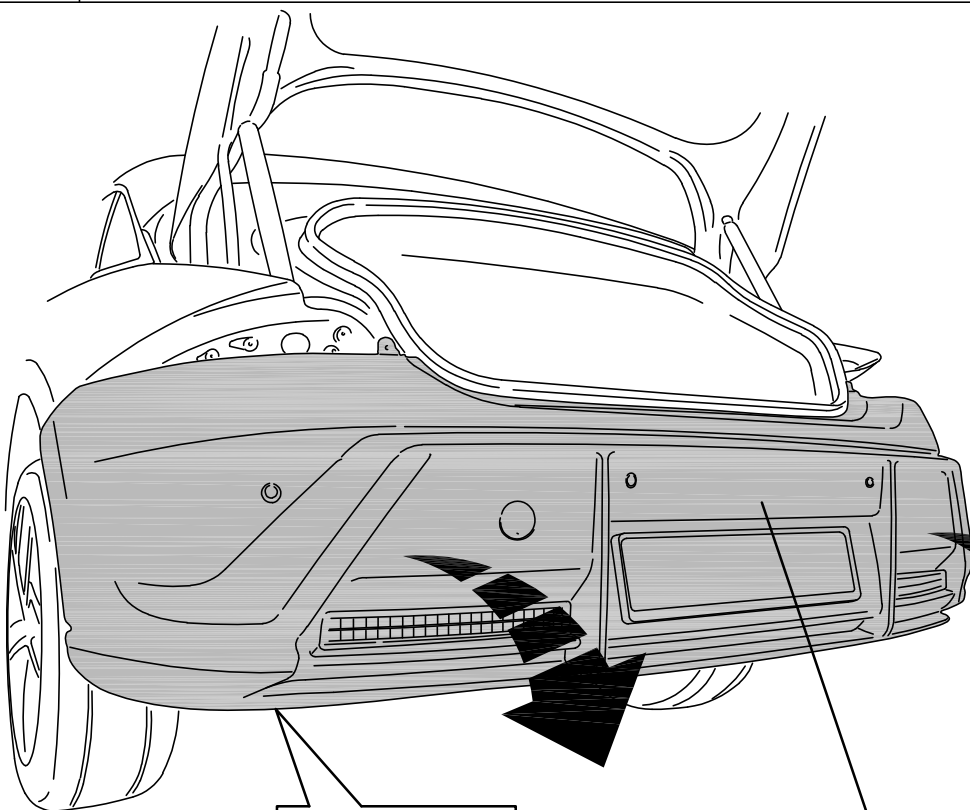
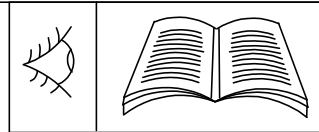

X12

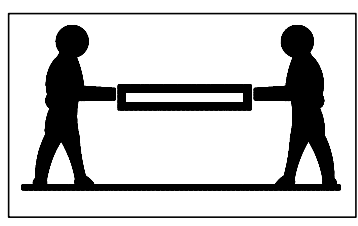

9

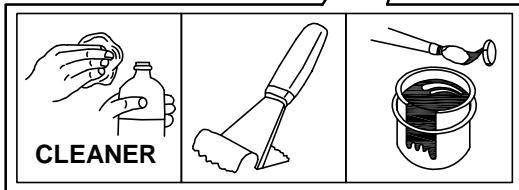
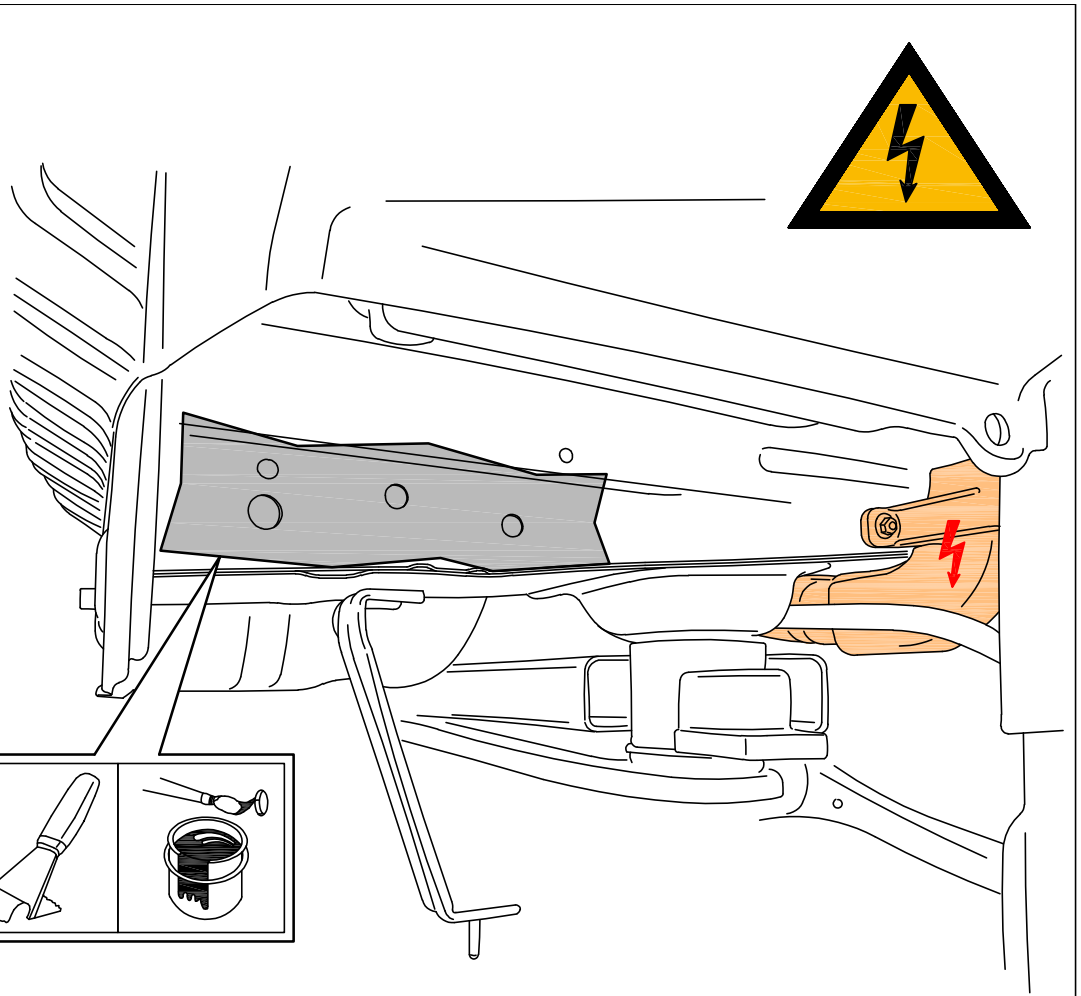
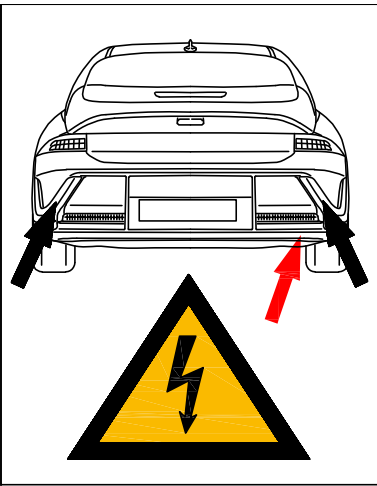

10

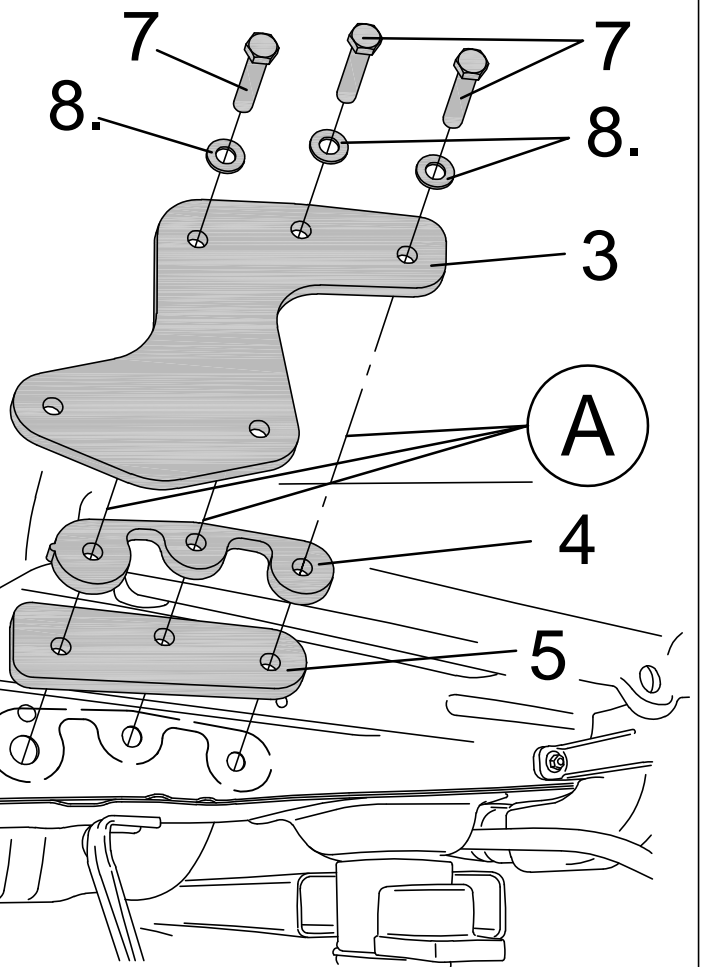
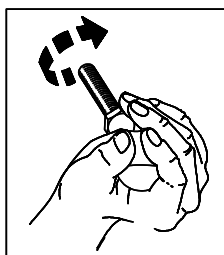
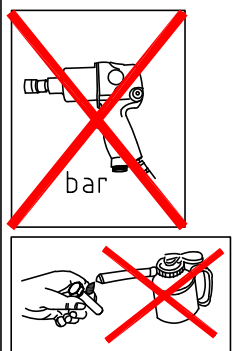
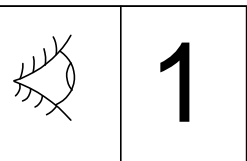
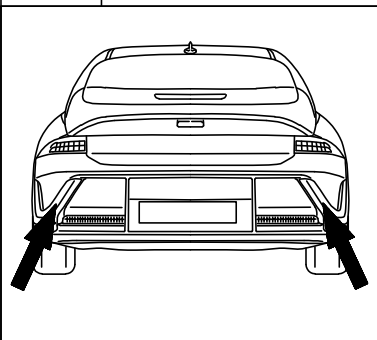

11

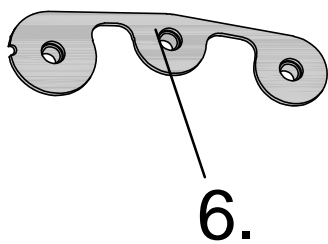

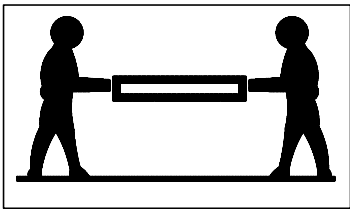

1

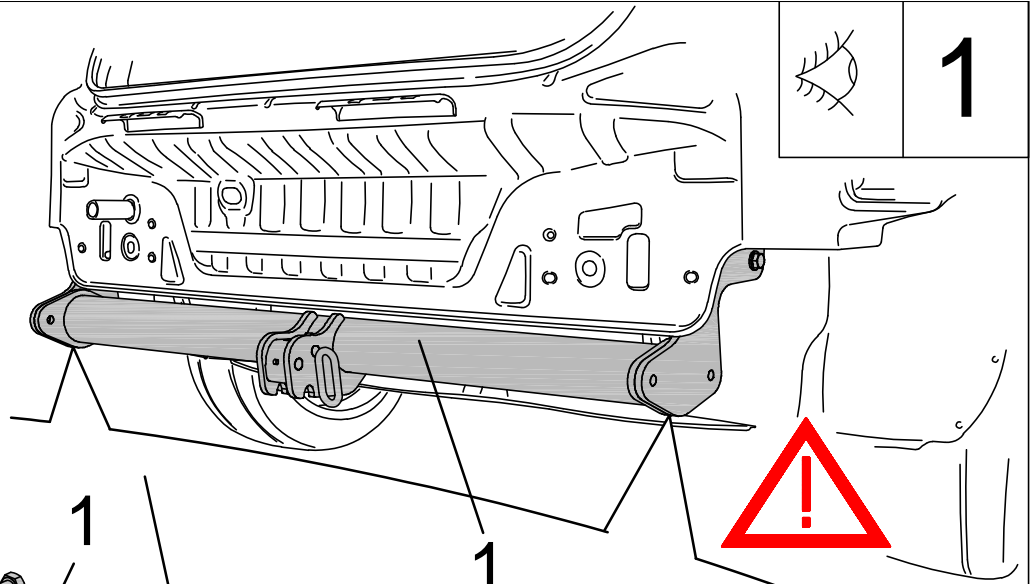
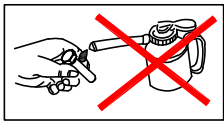
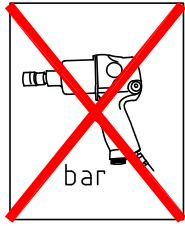
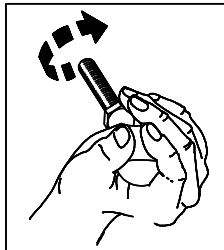

12

10

9.

9.

B

8.

9.

1

8.

9.

9.

10

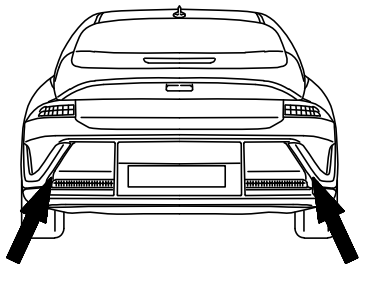

	M12	10.9	100Nm
--	-----	------	-------

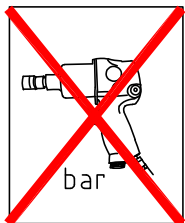

13

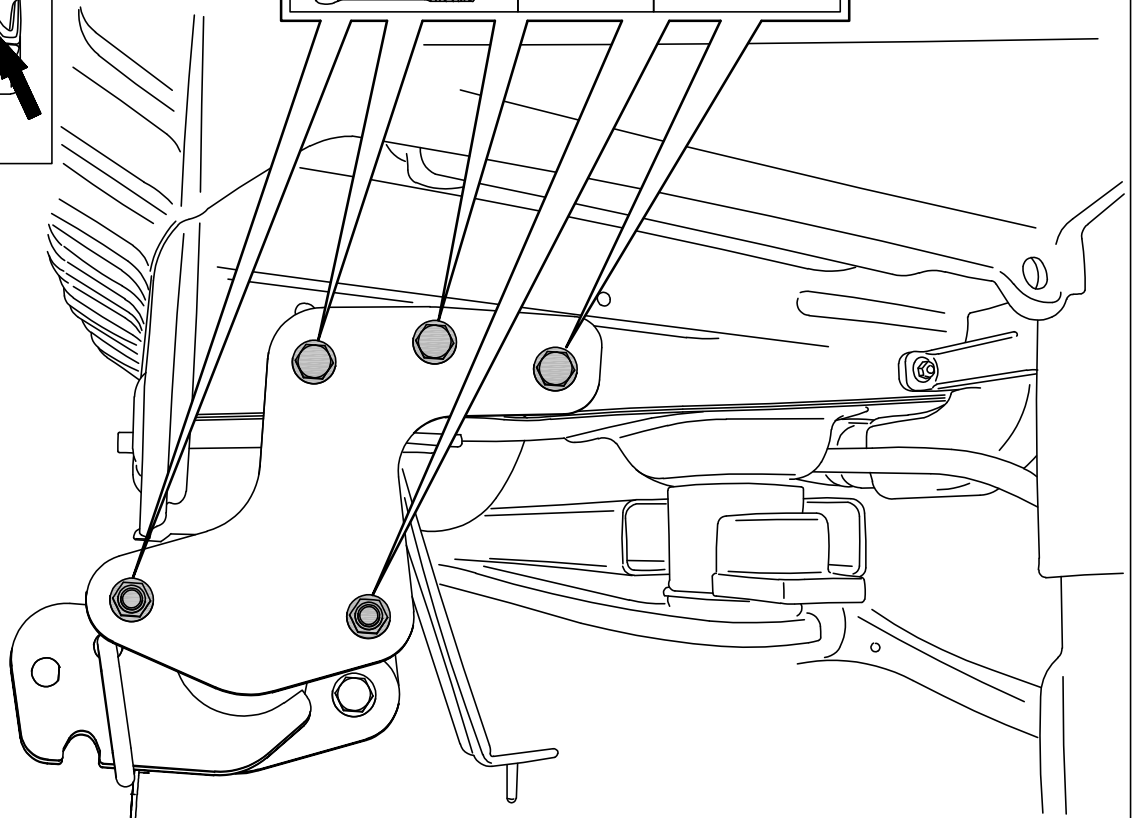

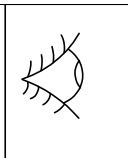
 **1**

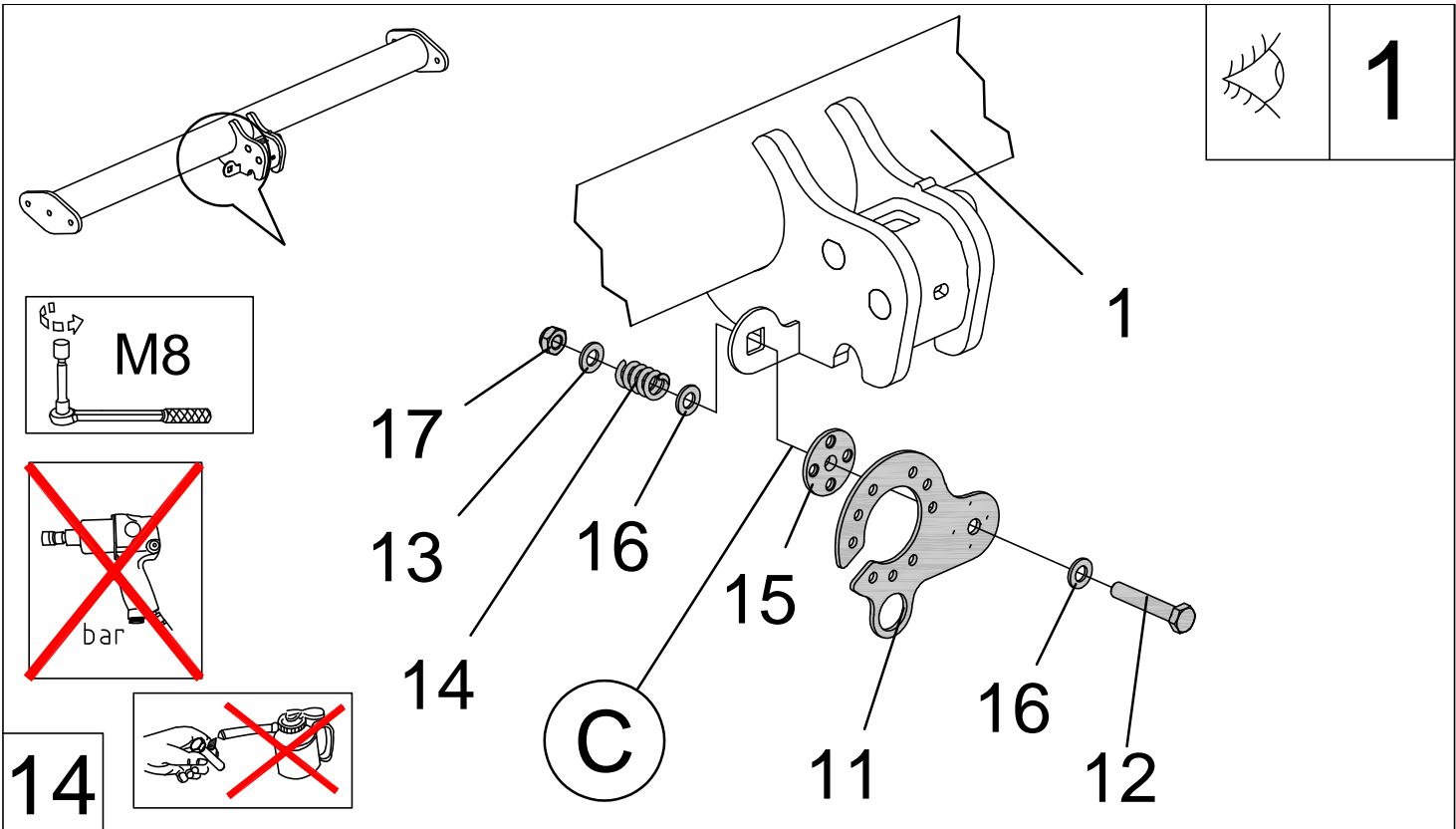

**⚠ Vor der Komplettierung des Fahrzeuges ist der Elektrosatz zu montieren! ⚠**

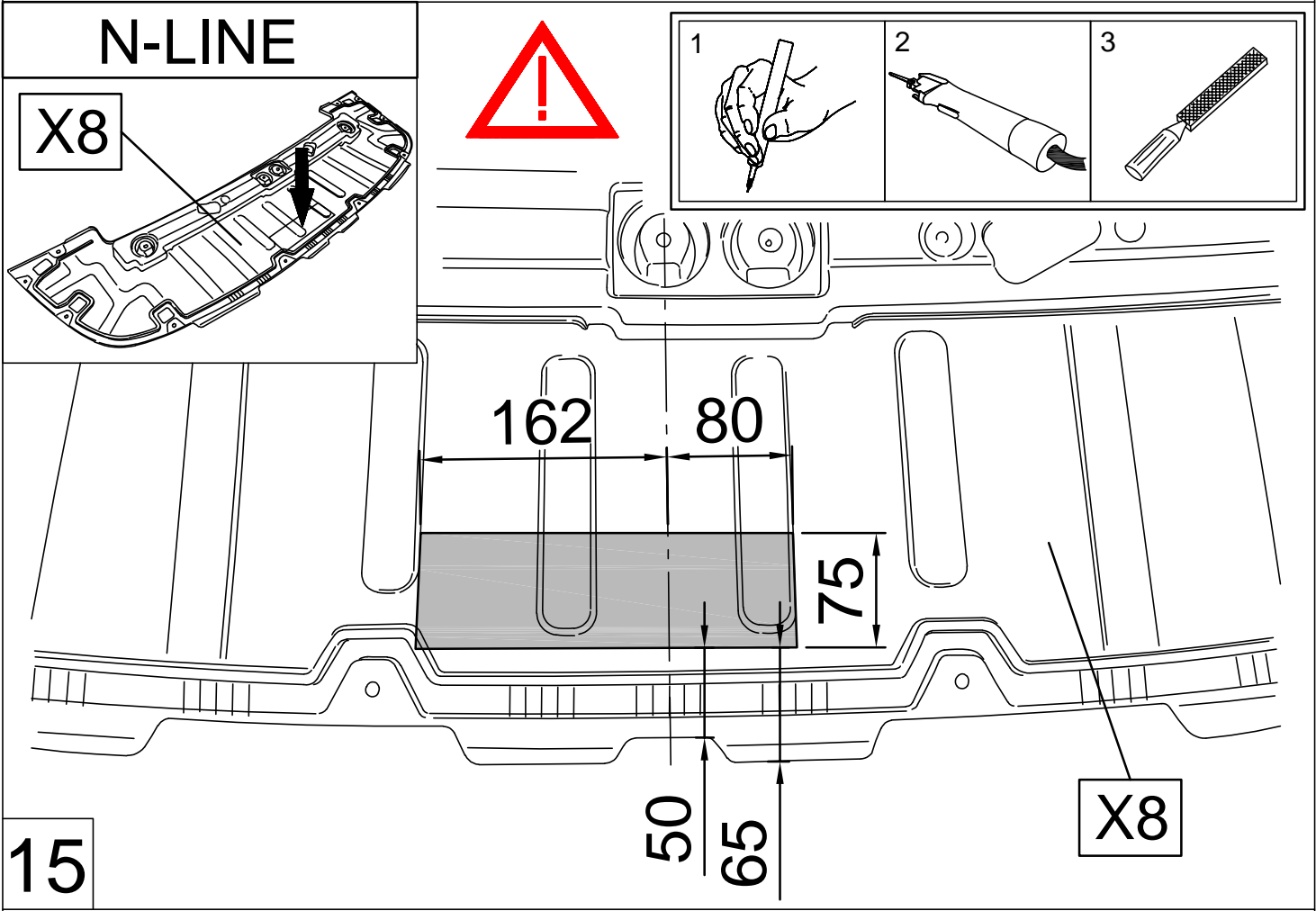

**15**

# FACELIFT

X8

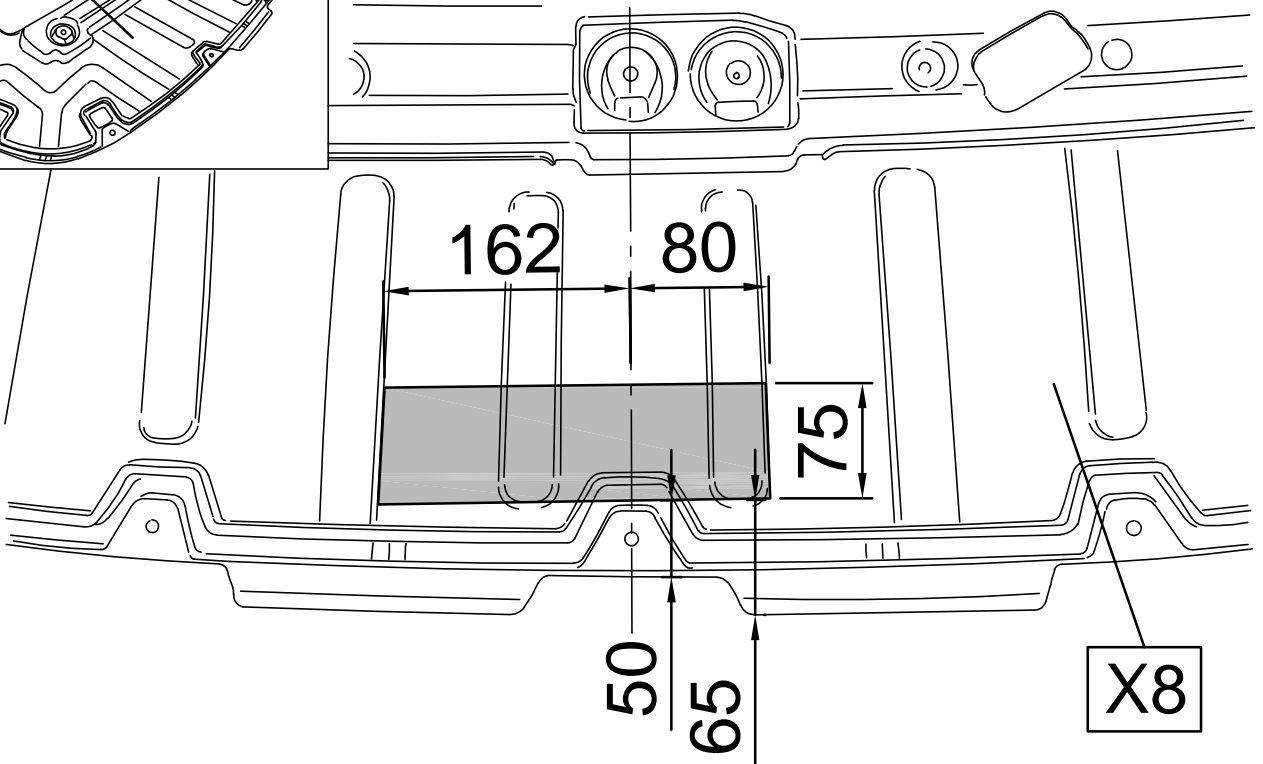
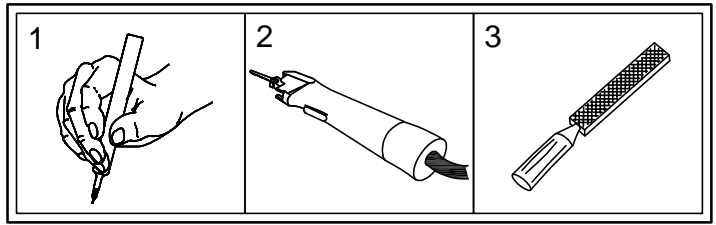
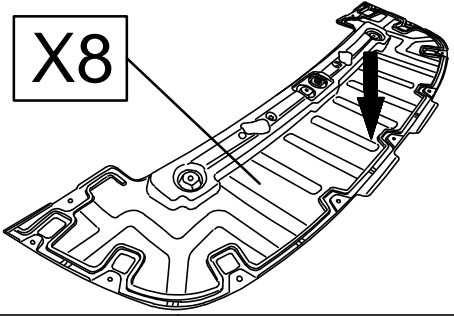

16

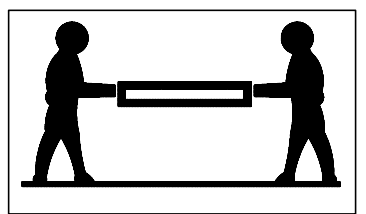
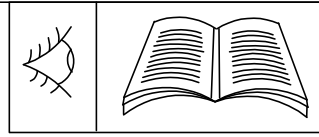
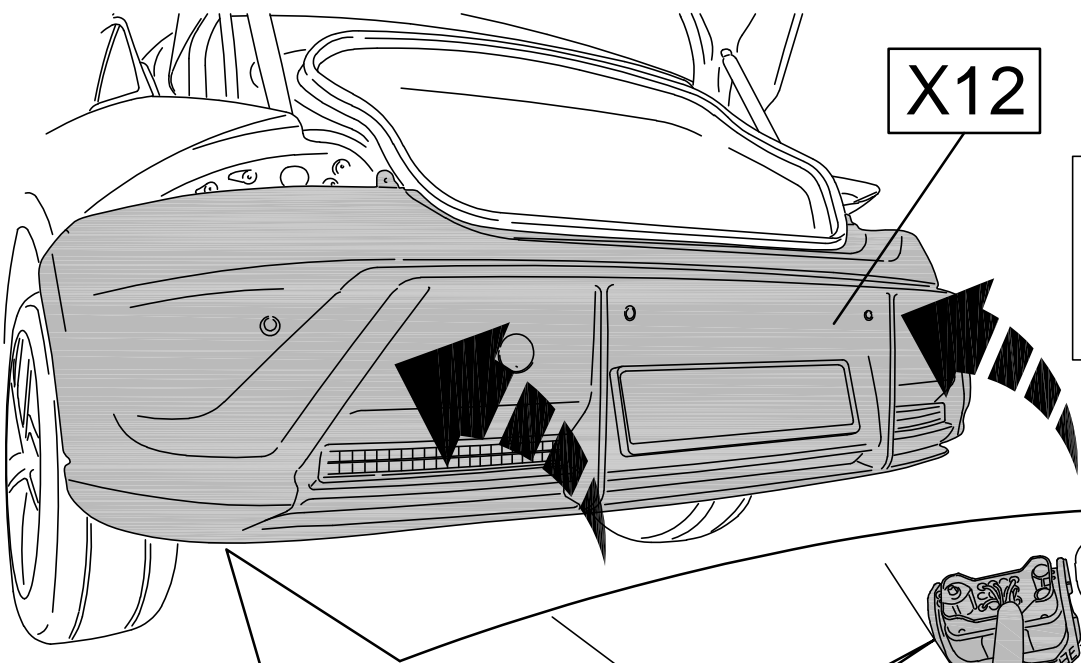

17

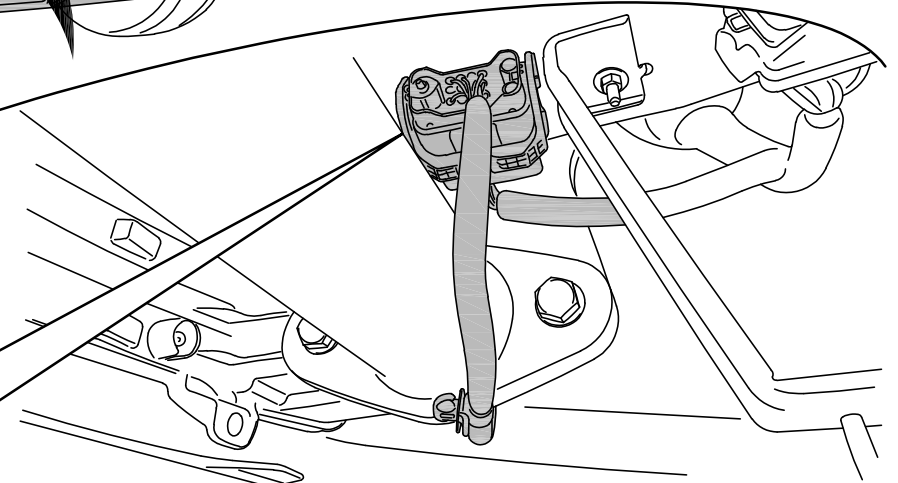
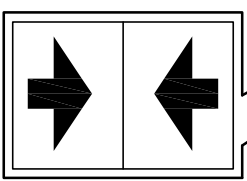
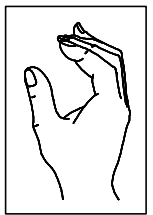

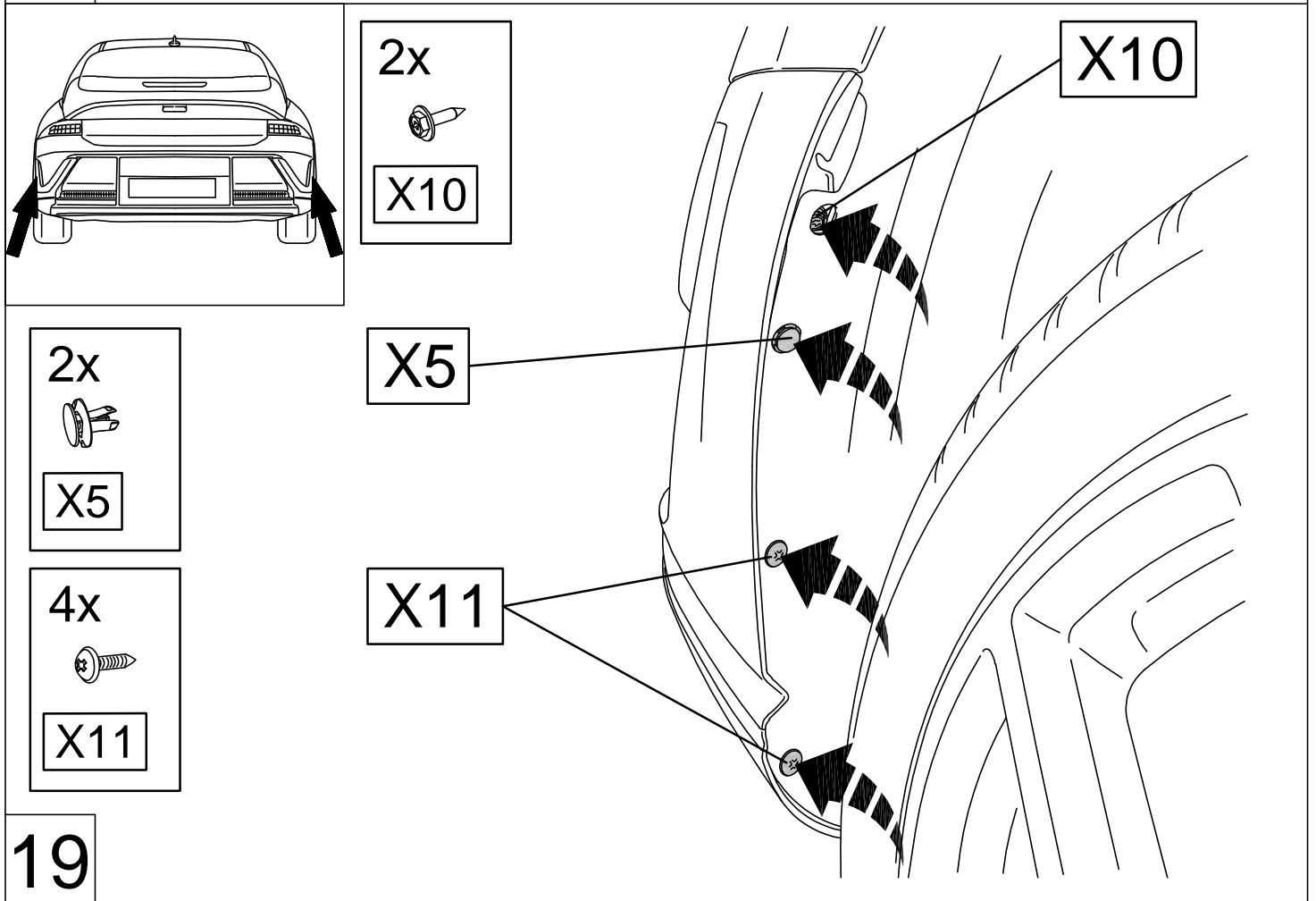
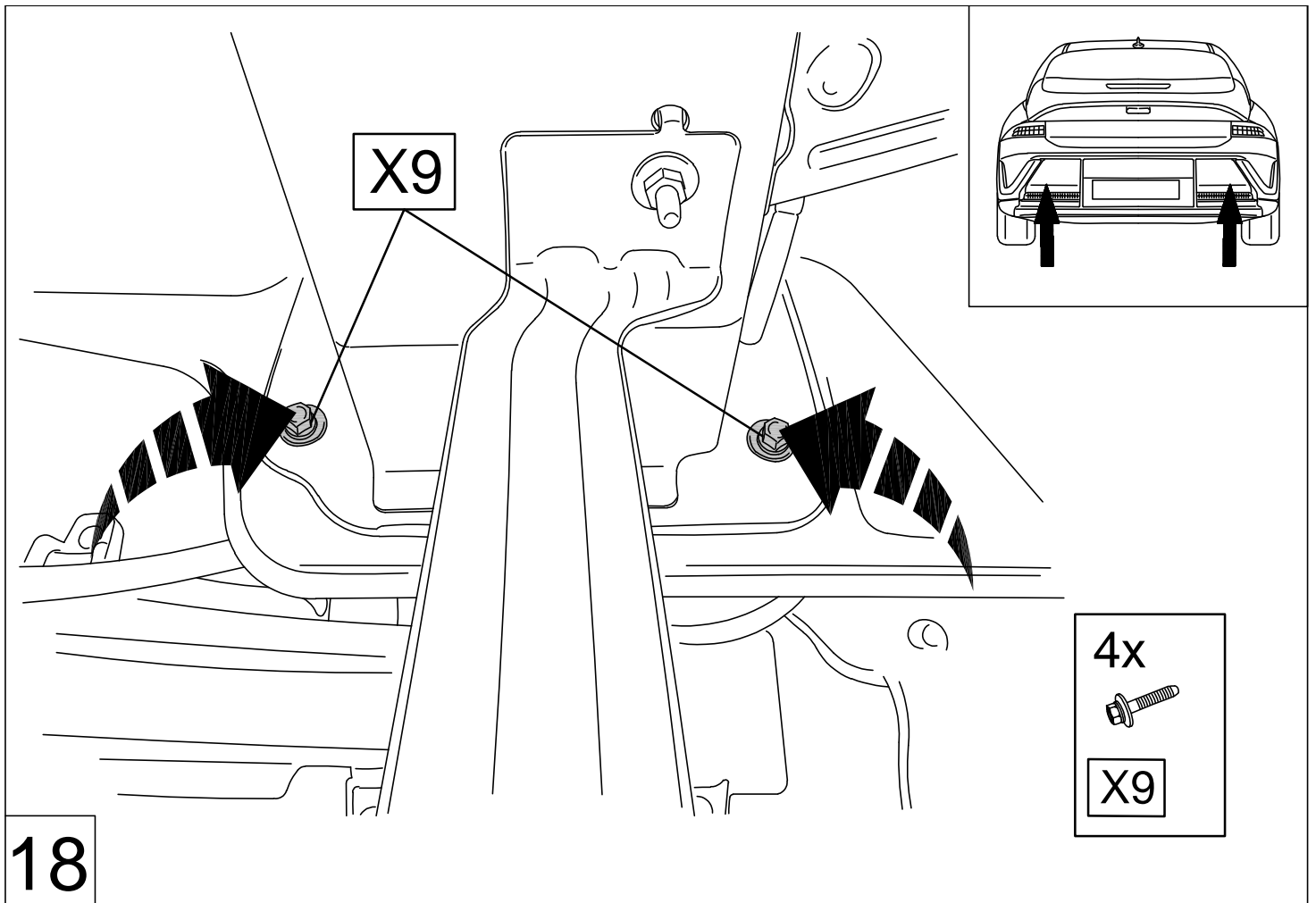

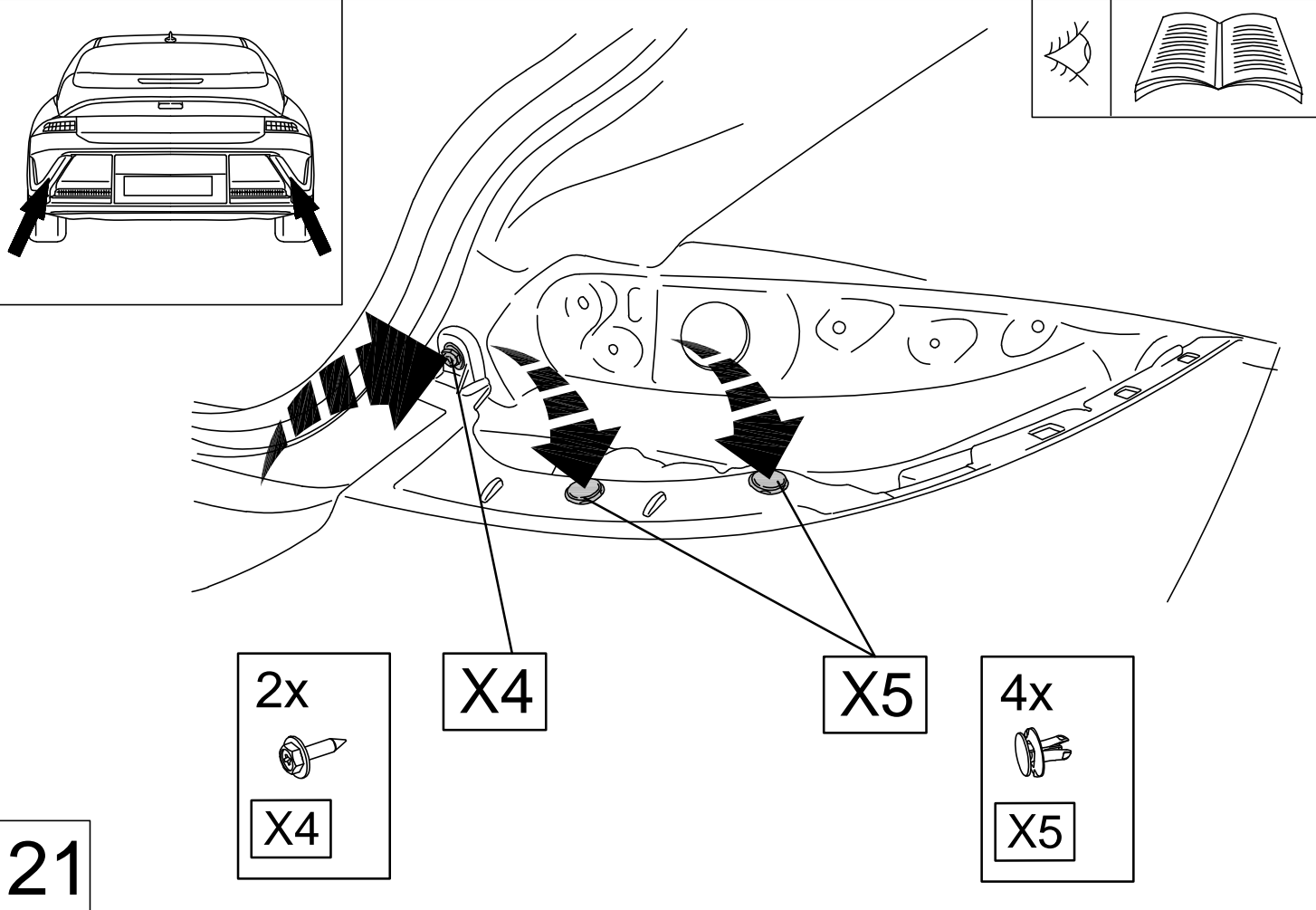
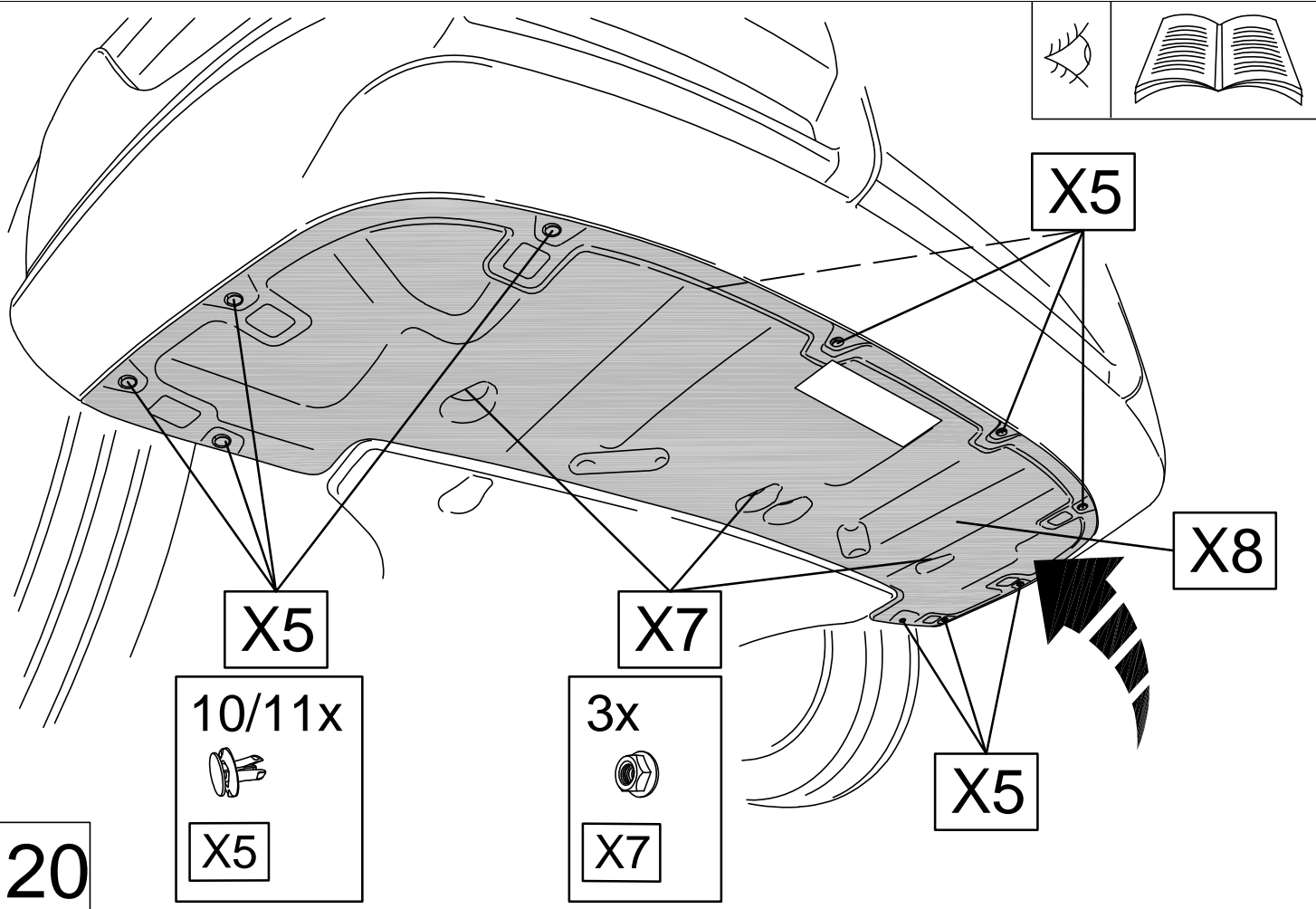

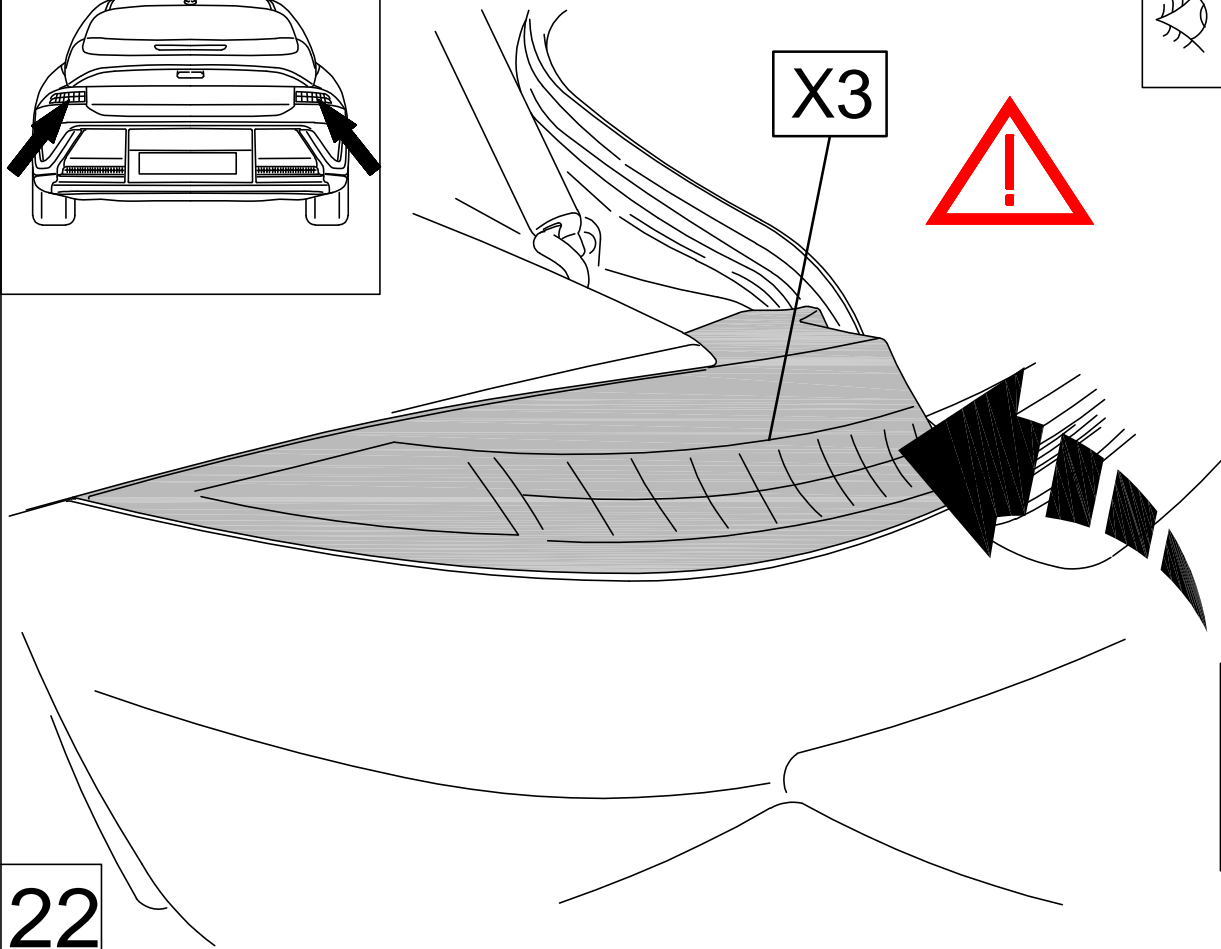
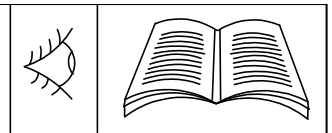
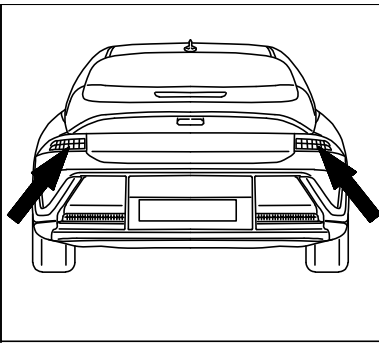

22

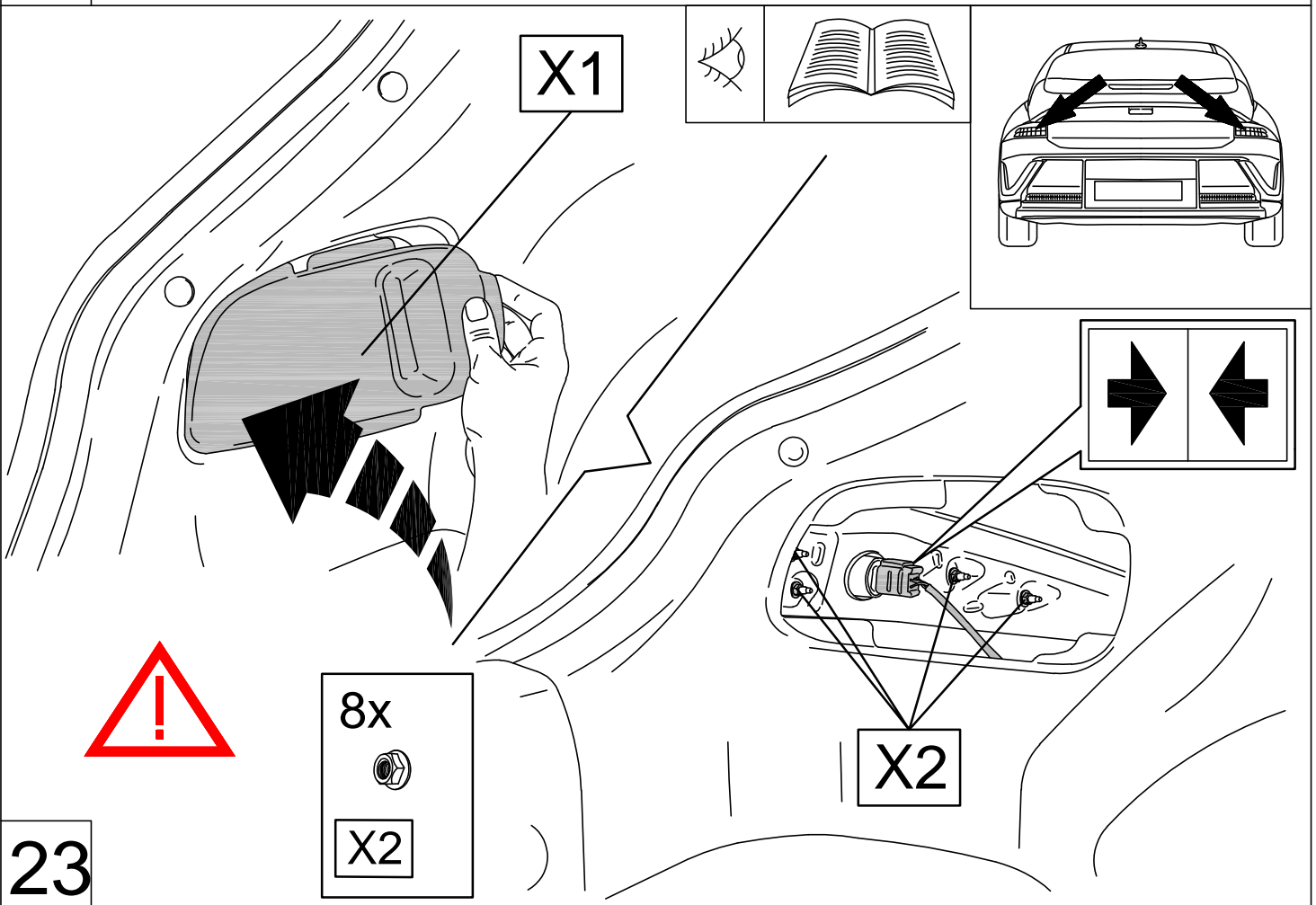

23

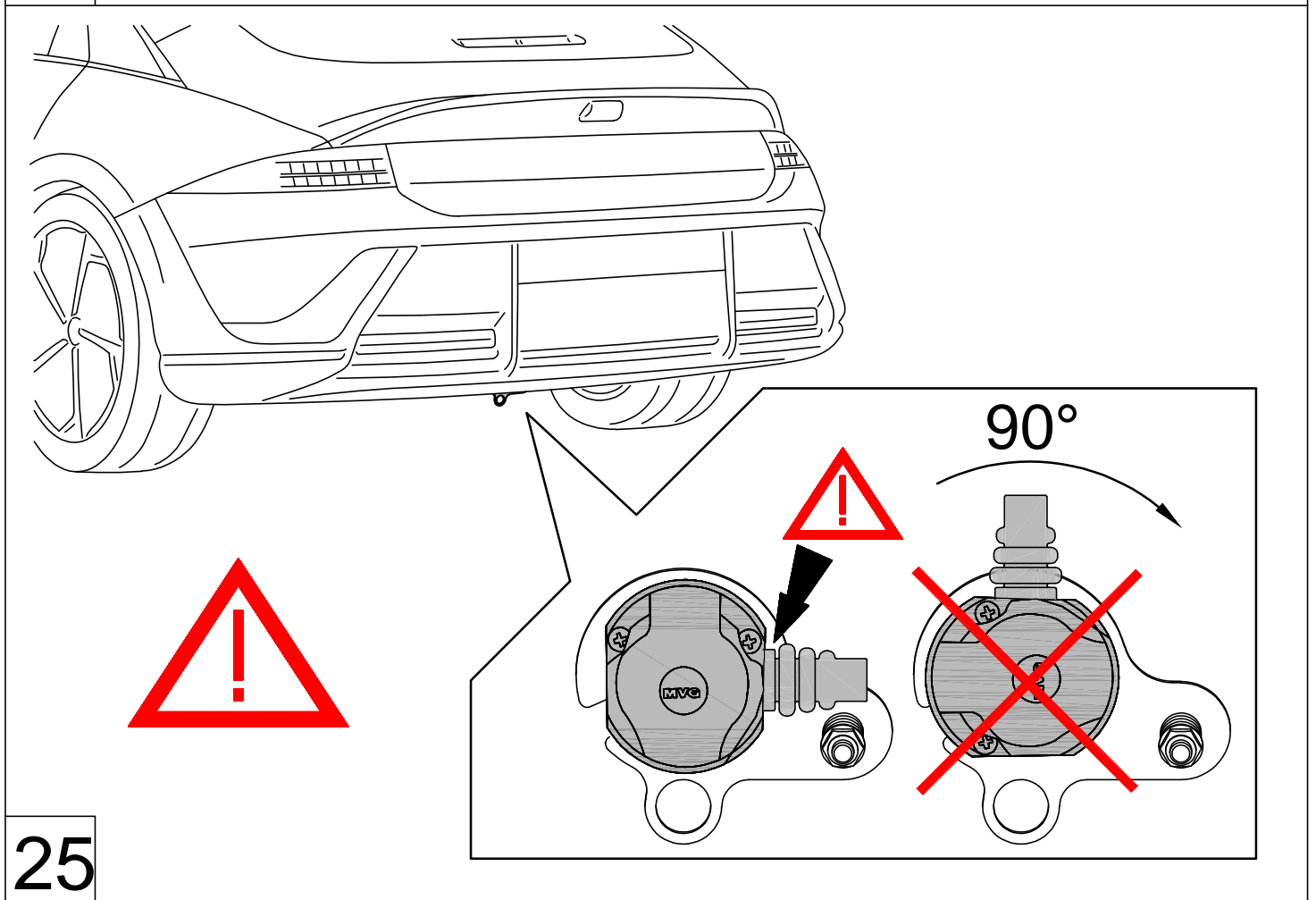
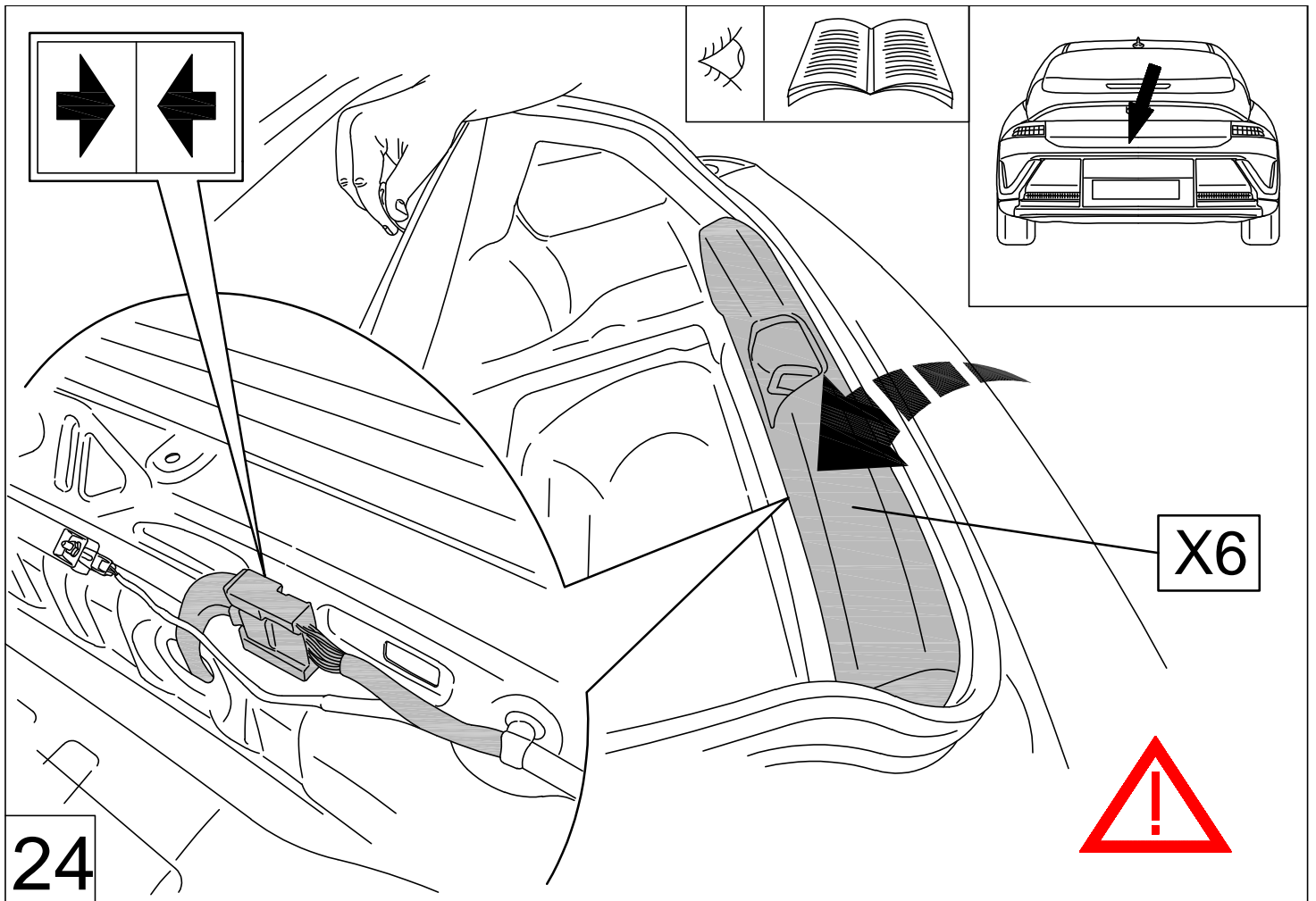

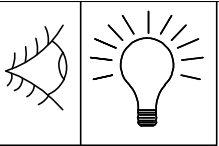

Zulässige Stützlast  
maximal 100 kg  
**MVG**  
www.mvg-ahk.de

21

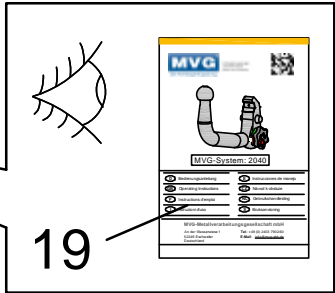
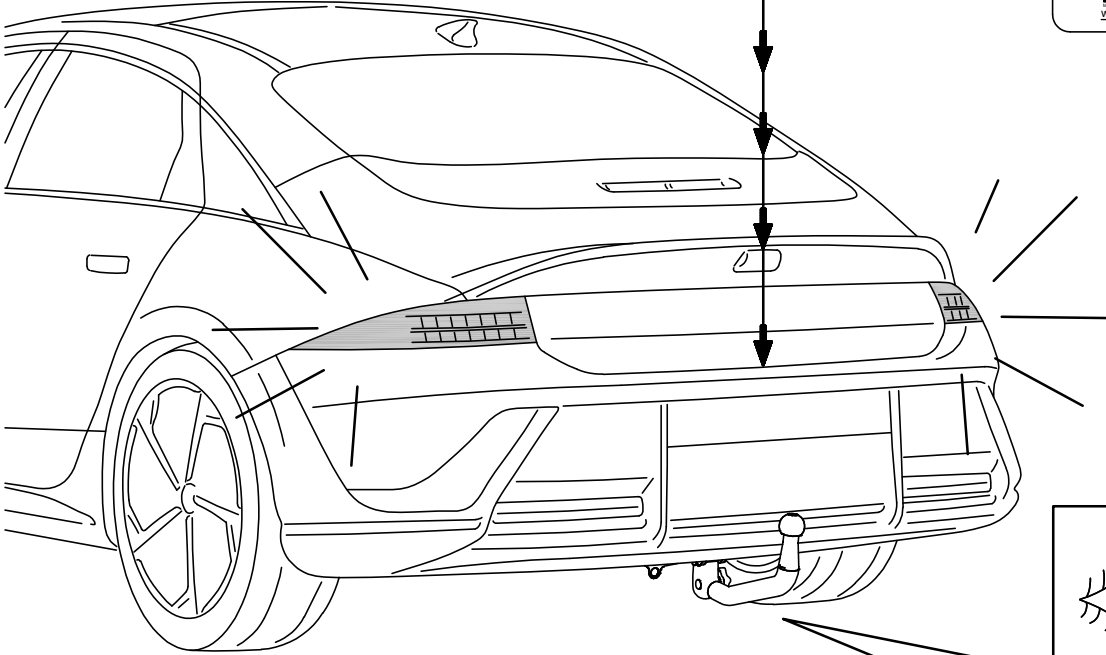

24

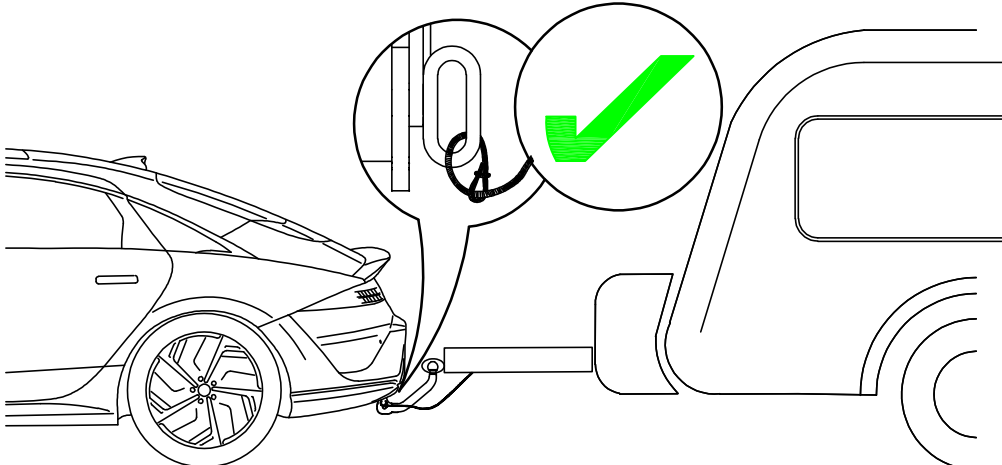
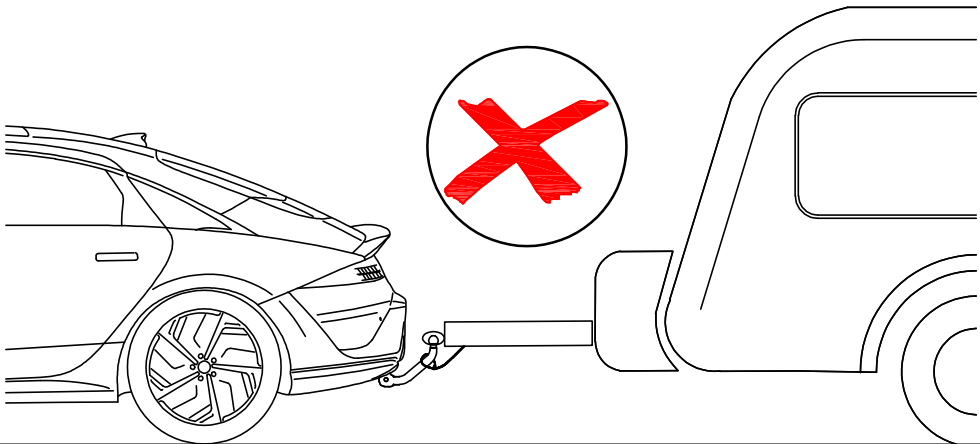

25

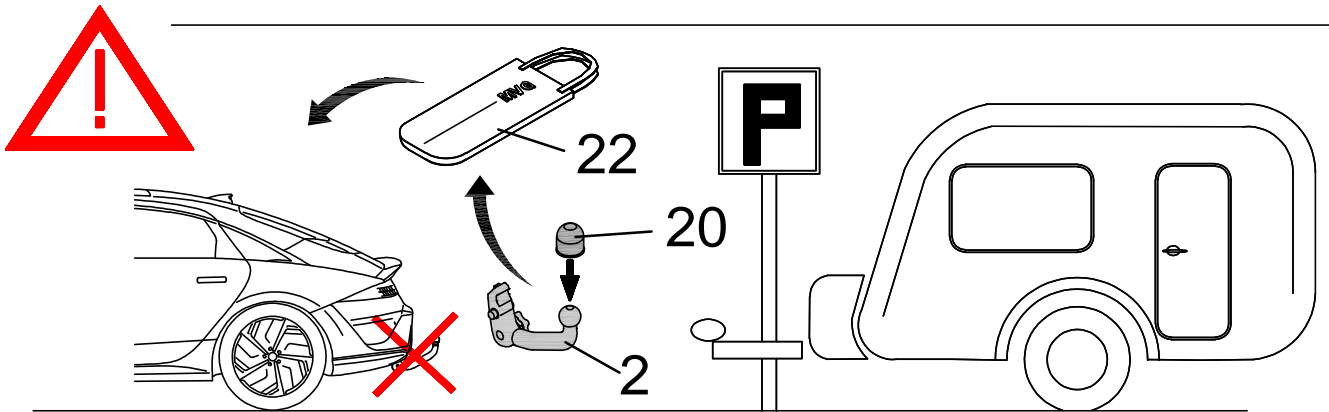
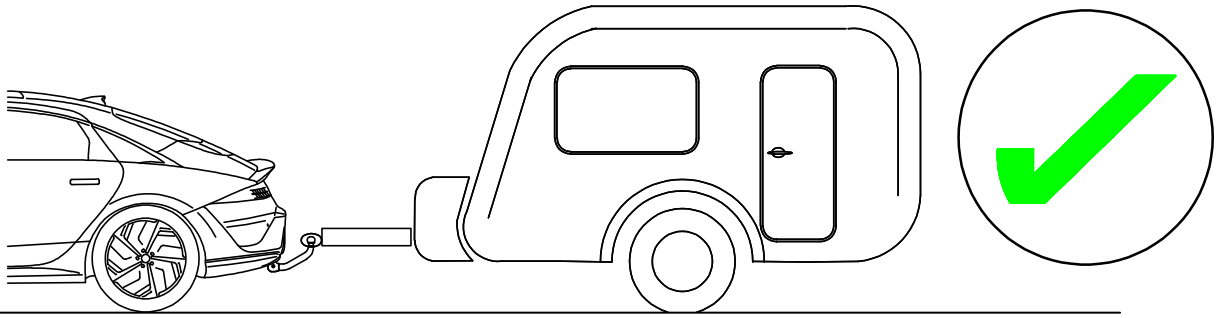

24

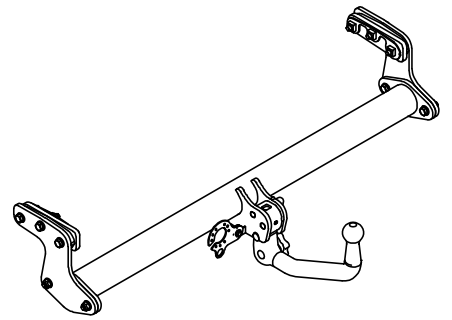
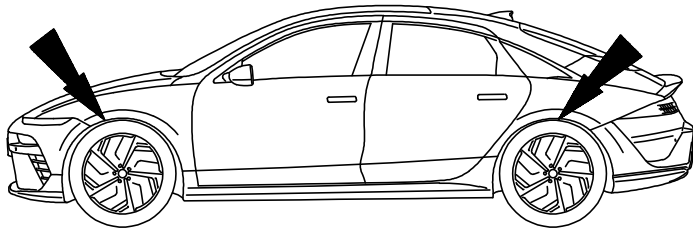

Best. Nr.: 3163 A

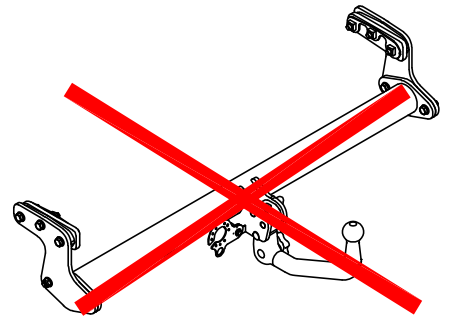
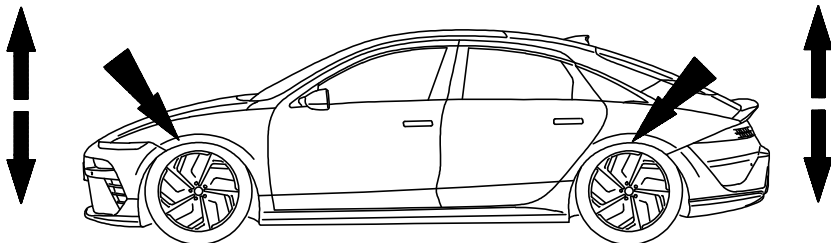

25



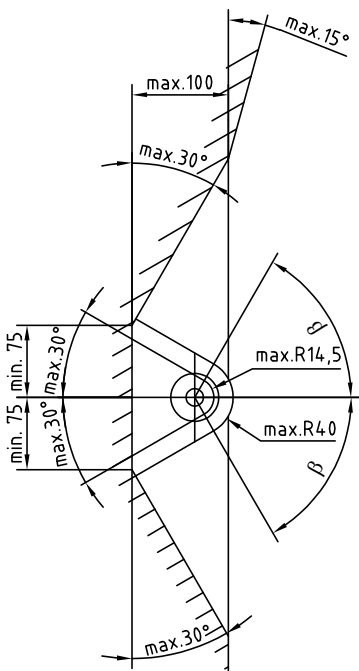
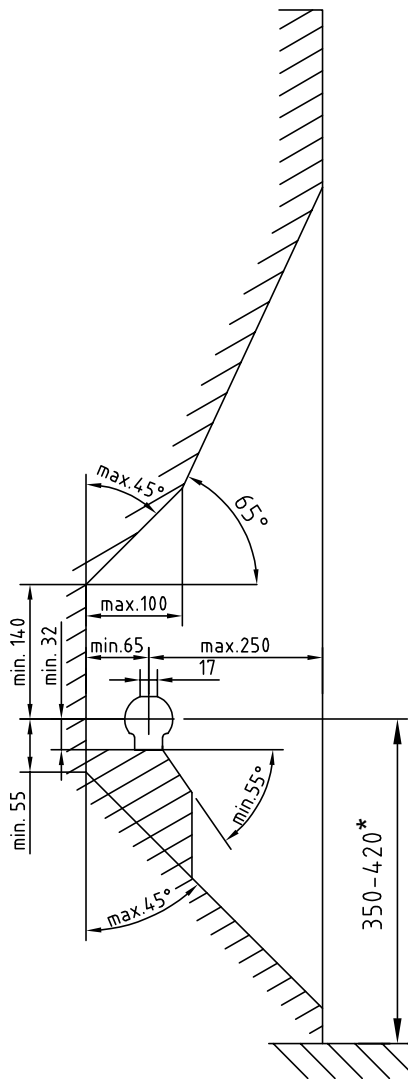

- D** Der Freiraum nach Anhang 7, Abbildung 25a und 25b der Richtlinie ECE-R 55 ist zu gewährleisten.
- CZ** Volný prostor ve smyslu Přílohy 7, obr. 25a a 25b směrnice ECE-R 55 musí být zaručen.
- DK** Det skal sikres, at der er spillerum i overensstemmelse med bilag 7, fig. 25a og 25b i henhold til direktiv ECE-R 55.
- E** Hay que garantizar el espacio libre conforme al anexo 7, fig. 25a y 25b de la directiva ECE-R 55.
- F** La zone de dégagement, selon l'annexe 7, figure 25a et 25b de la directive ECE-R 55, doit être assurée.
- FIN** Välyksen tulee täyttää ohjeen ECE-R 55 liitteen 7 kuvissa 25a ja 25b ilmoitetut vaatimukset.
- GB** Make sure to provide clearance according to appendix 7, figures 25a and 25b of the ECE-R 55 regulations.
- GR** Πρέπει να εξασφαλίζεται ο ελεύθερος χώρος σύμφωνα με το παράρτημα 7, σχήμα 25a και 25b της κοινοτικής οδηγίας ECE-R 55.
- H** Biztosítani kell az ECE-R 55 irányelv szerinti, 7. számú függelék, 25a. és 25b ábrákban jelölt szabad teret.
- I** Deve essere garantito lo spazio libero secondo l'allegato 7, figure 25a e 25b della normativa europea ECE-R 55.
- N** Det må sørges for fritt rom i samsvar med tillegg 7, figur 25a og 25b i direktiv ECE-R 55.
- NL** De vrije ruimte volgens supplement 7, afbeelding 25a en 25b van richtlijn ECE-R 55 moet gewaarborgd zijn.
- PL** Należy zapewnić wolną przestrzeń zgodnie z załącznikiem 7, rys. 25a i 25b, dyrektywy ECE-R 55.
- RUS** Оставлять свободное пространство согласно Приложению 7, рис. 25a и 25b Директивы ECE-R 55.
- S** Spelrummet enligt bilaga 7, bild 25a och 25b i riktlinje ECE-R 55, måste garanteras.

- D** \* bei zulässigem Gesamtgewicht des Fahrzeuges
- CZ** \* při celkové přípustné hmotnosti vozidla
- DK** \* ved tilladt totalvægt for køretøjet
- E** \* con peso total autorizado del vehículo
- F** \* pour poids total en charge autorisé du véhicule
- FIN** \* Ajoneuvon suurimmalla sallitulla kokonaispainolla
- GB** \* at gross vehicle weight rating
- GR** \* για το επιτρεπτό μικτό βάρος του οχήματος
- H** \* A jármű megengedett összsúlya esetén
- I** \* per il peso complessivo ammesso del veicolo
- N** \* ved kjøretøyets tillatte totalvekt
- NL** \* bij toegestaan totaal gewicht van het voertuig
- PL** \* przy dopuszczalnym ciężarze całkowitym pojazdu
- RUS** \* при допустимом общем весе автомобиля
- S** \* vid fordonets tillåtna totalvikt

- D** Die Anhängervorrichtung ist ein Sicherheitsteil und darf nur von Fachunternehmen montiert werden. Bei falscher Montage besteht schwere Unfallgefahr! Der deutsche Text dieser Anleitung ist bindend.
- CZ** Tažné zařízení je bezpečnostní součást, kterou smí montovat pouze odborné podniky. Při chybné montáži hrozí vážné nebezpečí nehody! Německý text tohoto návodu je závazný.
- DK** Anhængertrækket er en sikkerhedsdel og må kun monteres af autoriserede firmaer. Ved forkert montering er der fare for alvorlige uheld! Den tyske tekst i denne vejledning er bindende.
- E** La bola de enganche es un elemento de seguridad y sólo se debe permitir su montaje a personal cualificado. ¡En caso de montaje erróneo existe peligro de accidentes graves! Es vinculante el texto alemán de estas instrucciones.
- F** Le dispositif d'attelage est un équipement de sécurité et doit être mis en place exclusivement par un atelier spécialisé. Un montage incorrect représente un risque élevé d'accident! Le texte allemand de cette notice fait foi.
- FIN** Vetolaite on turvallisuuteen vaikuttava osa, jonka saa asentaa vain alan erikoisliike. Virheellinen asennus voi aiheuttaa vakavan onnettomuuden! Tämän ohjeen saksankielinen teksti on sitova.
- GB** A trailer hitch is a safety-critical part and may be fitted only by qualified companies. Improper assembly may result in a serious accident hazard! The German text of this instruction is binding.
- GR** Ο κοτσαδόρος είναι ένα εξάρτημα ασφαλείας και η τοποθέτηση του επιτρέπεται να γίνεται μόνο από εξειδικευμένο συνεργείο. Σε περίπτωση λάθους τοποθέτησης υπάρχει κίνδυνος σοβαρών ατυχημάτων! Το γερμανικό κείμενο αυτών των οδηγιών είναι δεσμευτικό.
- H** A vonószerkezet egy biztonsági felszerelés, amelyet csak szaküzem szerelhet fel. Helytelen szerelés súlyos balesethez vezethet! A német szerelési utasítás betartása kötelező.
- I** Il gancio di traino è un componente di sicurezza e deve essere montato esclusivamente da personale specializzato. In caso di montaggio errato sussiste il pericolo di incidenti gravi! È vincolante il testo tedesco di queste istruzioni.
- N** Tilhengerfestet er en sikkerhetskompoment og skal monteres av fagbedrift. Det er stor fare for at det kan oppstå ulykker ved feil montering! Den tyske teksten i denne veiledningen er bindende.
- NL** De aanhanger is veiligheidsonderdeel en mag alleen door vakkundig personeel worden gemonteerd. Bij verkeerde montage bestaat ernstig gevaar voor ongevallen! De Duitse tekst van deze handleiding is bindend.
- PL** Hak holowniczy stanowi element bezpieczeństwa i może zostać zamontowany wyłącznie przez firmę specjalistyczną. W przypadku nieprawidłowego montażu istnieje poważne ryzyko wypadku! Tekst niniejszej instrukcji w języku niemieckim jest wiążący.
- RUS** Сцепное устройство - это узел, несущий предохранительные функции, и к его монтажу допускаются только специалисты. При неправильном монтаже грозит опасность тяжелых травм! Обязательным является немецкий текст данной инструкции.
- S** Dragkroken är en säkerhetskompoment och bör endast monteras av kvalificerade tekniker. Vid felaktig montering föreligger risk för allvariga olyckor! Den tyska texten i denna anvisning är bindande.

Dispositivo di traino tipo:

**3163 A**

Per autoveicoli:

**Hyundai IONIQ 6 Facelift / N-Line Mj 2026 à**

Tipo funzionale:

**CE**

Classe e tipo di attacco:

**CLASS A50-X**

Omologazione:

**E4 55R-03 1476**

Valore D:

**10,0 kN**

Carico verticale max. S:

**100 kg**

Larghezza rimorchiabile per Caravan e T.A.T.S.: 2,45 m vedere CARTA di CIRCOLAZIONE VEICOLO (mattice) + 70 cm = arrotondare ai 5 cm superiore (vedi D.M. 28/05/85)

Massa rimorchiabile:

**Vedi carta circolazione dell' autoveicolo**

$$D = ((T \times C) / (T+C)) \times 0,00981 = 10,0 \text{ kN} < D$$

Per verificare l'idoneità del dispositivo di traino omologato a norma ECE-R55, all'installazione sulla vettura su cui si intende procedere al montaggio, compilare la seguente formula (se necessario declassare la massa rimorchiabile):

dove: T = Massa Complessiva Max. della motrice (in kg)  
C = Massa Rimorchiabile Max. della motrice (in kg)

### DA COMPILARE PER IL COLLAUDO

**DICHIARAZIONE DI CORRETTO MONTAGGIO:** la sottoscritta Ditta dichiara di aver montato in maniera corretta ed in conformità alle prescrizioni sia del costruttore del veicolo che del costruttore del dispositivo stesso il seguente dispositivo di attacco meccanico:

Tipo: .....

Il dispositivo di attacco sopra indicato è stato installato su autoveicolo

Modello: .....

Targa: .....

Data: .....

**TIMBRO e FIRMA**

Si dichiara inoltre di aver informato l'utente del veicolo sull'USO e MANUTENZIONE del dispositivo stesso.





Die Bedienungsanleitung als Video finden Sie unter folgendem Link:

This instruction manual can be found as an illustrating video under the following link:

<https://mvg.li/2040>

Außerdem können Sie mit Ihrem Smartphone den Video-Link durch diesen QR-Code direkt scannen und das Video ansehen.

Furthermore, the link to the video can be scanned and watched via this QR code by the use of your smartphone.



[www.mvg-ahk.com](http://www.mvg-ahk.com)